

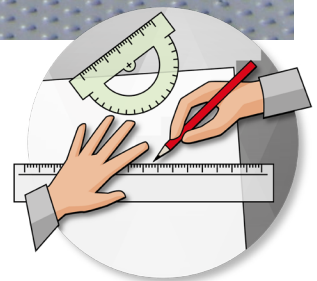

Artira

Design and Planning Guide



Please note:

Dimensions provided in this Guide are for **REFERENCE ONLY** and should not be used for site preparation or construction.

Table of Contents

What is an Inclined Platform Lift?	4
Why a GSL Artira?	4
Design Versatility	4
Finishes	6
Where You'll Find Our Lifts	6
How it Works	7
Component Identification	8
Platform Specifications	9
Standard Platform Features	10
Optional Platform Features	11
Call Stations	12
Lower Landing Configuration Options	13
Required Turning Clearances	15
Turning Clearance Chart	16
Standard Upper Landing Drive Configurations	17
Alternate Drive Configurations	19
Drive System	20
Additional Component Options	21
Guide Tubes	22
Platform Storage at Upper Landing (Optional)	23
Platform Running Clearances Required For Platform Folded Up	24
Minimum Overhead Clearances To Meet Code Requirements	24
Attachment Methods	26
Wall Height Requirements for Direct Mounting	28
Loading Diagram	29
Technical Reference of Standard Features	30
Typical Wiring Layout	31

What is an Inclined Platform Lift?

An inclined platform lift easily transports a passenger in a wheelchair, or someone who has difficulty using stairs. The lift can be operated independently or by an attendant with an attendant remote control (optional item). Compatible for indoor and outdoor applications, the **Garaventa Artira Inclined Platform Lift** is a versatile, attractive and cost-effective accessibility solution.

Why a GSL Artira?

- **Meets ADA Requirements** - Garaventa inclined platform lifts are approved as a means to provide public building access. Compliant to ASME A18.1 (USA) and CSA B355 (Canada).
- **The Established Benchmark** - Garaventa Lift has been designing and manufacturing inclined platform lifts since 1978. More Garaventa inclined platform lifts are installed in commercial buildings in North America than all other current manufacturers combined.
- **Minimal or No Stairway Modification** - The Artira will fit into most existing stairways and do not require specially constructed hoistways.
- **Space Saver** - The Artira does not permanently occupy valuable floor space and, when folded, is the most compact inclined lift available. It is also capable of turning tighter corners than any other lift on the market.
- **Safety** - The Artira is available with a large selection of safety and usability options. It is considered to be one of the most user-friendly inclined platform lifts available today.

Design Assistance

With over 35 years of experience, Garaventa Lift is willing and able to overcome almost any design challenge you face. Please call our Design Hot Line with your accessibility challenge.

1-800-663-6556 or 1+604-594-0422

Design Versatility

The GSL Artira can be designed for **turning, straight or radiating stairways** with or without **intermediate landings**. It is suitable for multi-level buildings with a wide variety of design configurations.

Some of the many design configurations include:

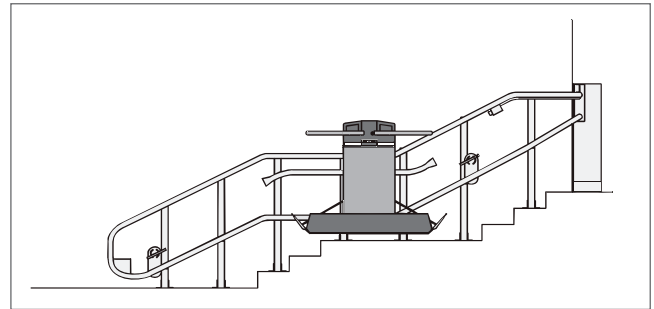

Straight Stairway With An Intermediate Horizontal Landing

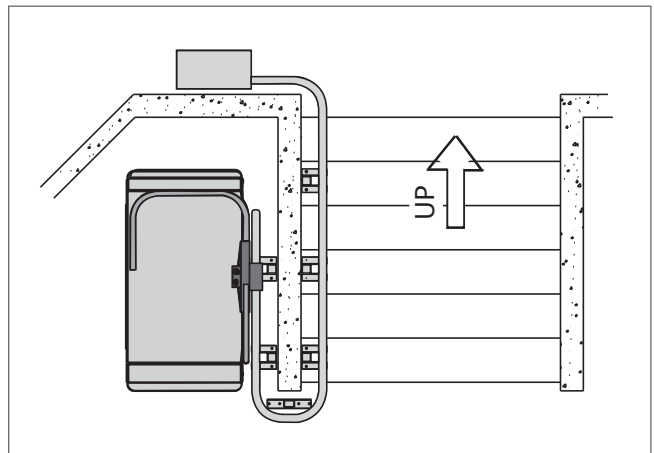

Straight Stairway With Platform Storage

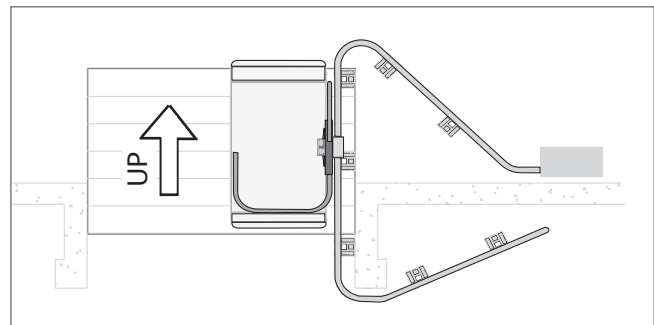

Unusual Bends:

For applications such as theaters, restaurants or lecture halls.

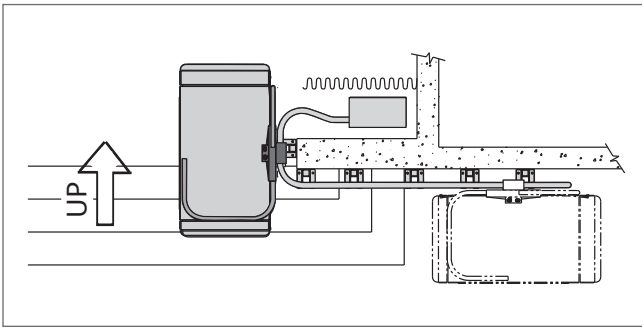

Unusual Landings:

An ideal layout for stages or store entrances.

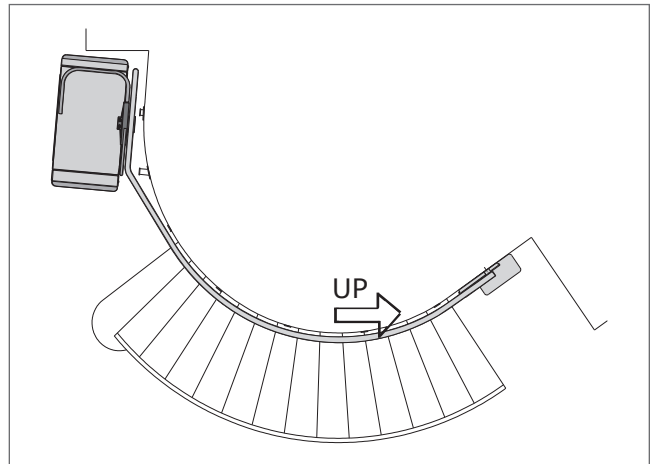

Radiating Stairs:

Found in installations such as hotel lobbies or observatories.

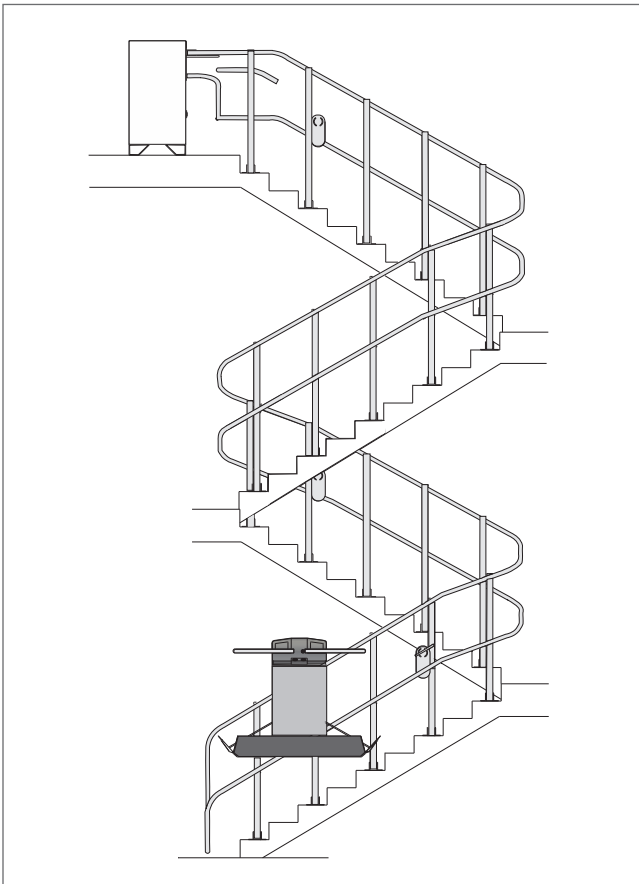

Turning Stairway In A Multi-Level Building

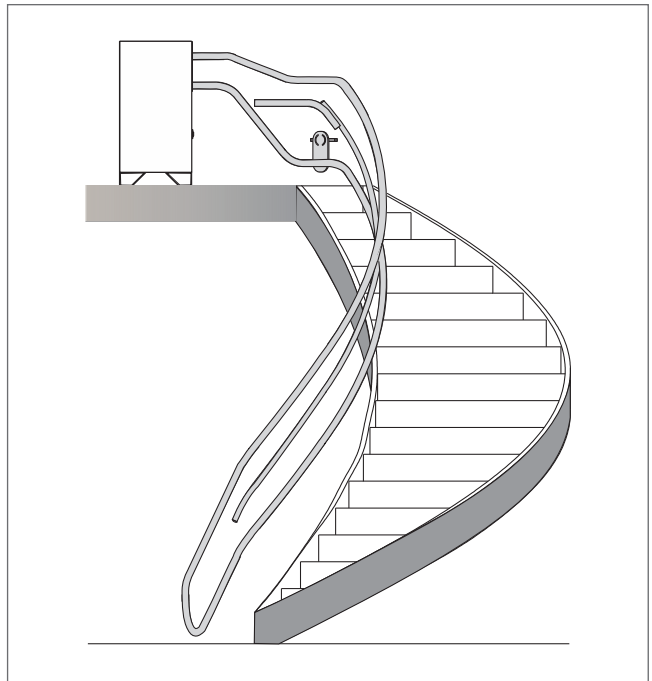

Spiral Stairs:

Grand staircases in hotels or theaters.

Applications Include:

- Schools
- Courthouses
- Theaters
- Restaurants
- Hospitals
- Churches
- Commercial Buildings
- Historical Buildings
- Residential
- And Many More

Finishes

The GSL Artira is finished in a durable polyester powder paint coating that is electrostatically applied and baked at 210° C (410° F).

Standard Color

Garaventa Lift's standard color, Satin Grey (fine textured), complements a variety of modern and traditional decors (color samples are available upon request).

Custom Colors (Optional)

Garaventa Lift offers a choice of colors from the internationally accepted RAL color charts (color samples are available upon request).

Stainless Steel Finish (Optional or for Outdoor Applications)

For aesthetic purposes the tubes, towers, drive box, sensing plate and call stations can be ordered in a combination brushed and electro-polished stainless steel finish. Tubes and towers are electro-polished whereas the drive box and sensing plates are brushed. Stainless steel components are also available with a powder coat painted finish.

Outdoor Applications

When located outdoors, the lift must be equipped with stainless steel outdoor compatible components. See page 21 for more information on the outdoor weather-resistant package. For outdoor units, stainless steel components are available in a painted finish.



Stainless Steel Tubes & Towers

Note: In certain indoor applications such as near a swimming pool, an outdoor weather-resistant package may be required.

Where You'll Find Our Lifts

Garaventa Lift has completed over 50,000 installations worldwide. Some of our well-known inclined lift installations include:

- National Art Gallery - Ottawa, ON, Canada
- Presidential Palace - Seoul, Korea
- City Hall, San Francisco, CA, USA
- #10 Downing Street - London, England
- The Peak - Hong Kong
- Madison Square Garden - New York, NY, USA
- Yankee Stadium - New York, NY, USA
- Harvard Business School - Cambridge, MA, USA
- Metro System - Santiago, Chile & Mexico City, Mexico
- BART (Bay Area Rapid Transit), San Francisco, CA, USA
- Safeco Field, Seattle, Washington, USA
- Minnesota Twins Ball Park - Minneapolis, MN, USA



Custom Colors (Optional)

How it Works

Two custom-designed **steel guide tubes** which are custom designed for each stairway support the **platform**. These tubes contain a continuous loop of **wire haul rope** that is

attached to the **upper carriage**. This carriage is mounted to the back of the platform through a slot in the upper tube. The **drive system**, consisting of an electric motor and **drive cog**, moves the wire haul rope and the wheelchair platform up and down the stairway.

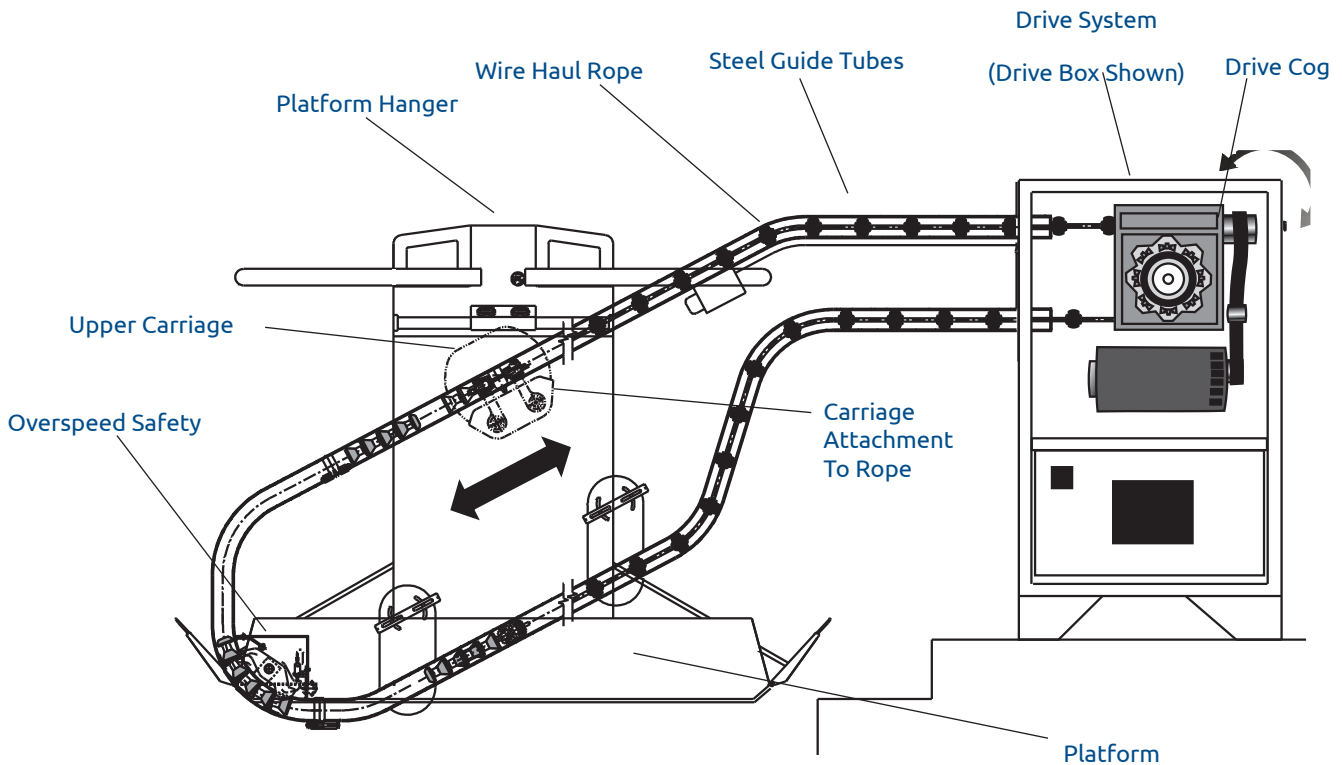

Section Through Tubes and Drive System

Overspeed Safety

The Overspeed Safety is located at the lower end of the tube system and consists of a mechanical pawl and electrical cut-out switch. In the unlikely event that the lift should descend too quickly, both the mechanical and electrical safety will activate simultaneously and stop the platform from moving.

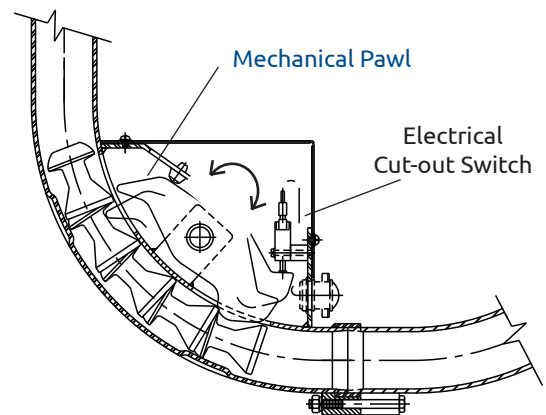

Overspeed Safety

Component Identification

The main components of an inclined lift are:
Platform, Drive, Guide Tubes, Call Stations

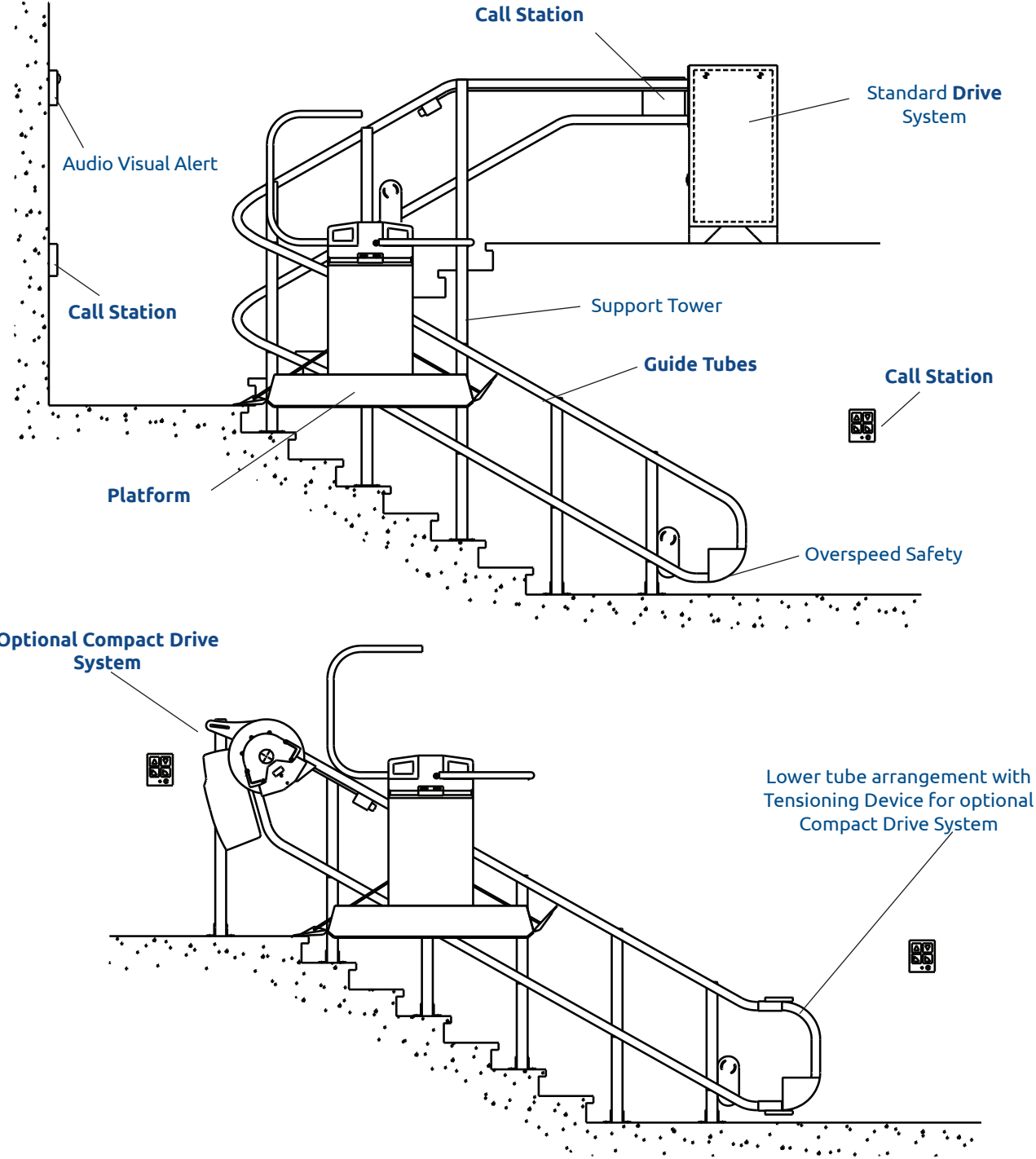

Platform Specifications

Platform Sizes

The platform is available in four sizes, all with a rated load of 300 kg. (660 lbs.).

- 800 x 1220mm (31 1/2" x 48")*
- 800 x 1050mm (31 1/2" x 41 3/8")
- 800 x 900mm (31 1/2" x 35 3/8")
- 700 x 750mm (27 1/2" x 29 1/2")

*ADA Compliant

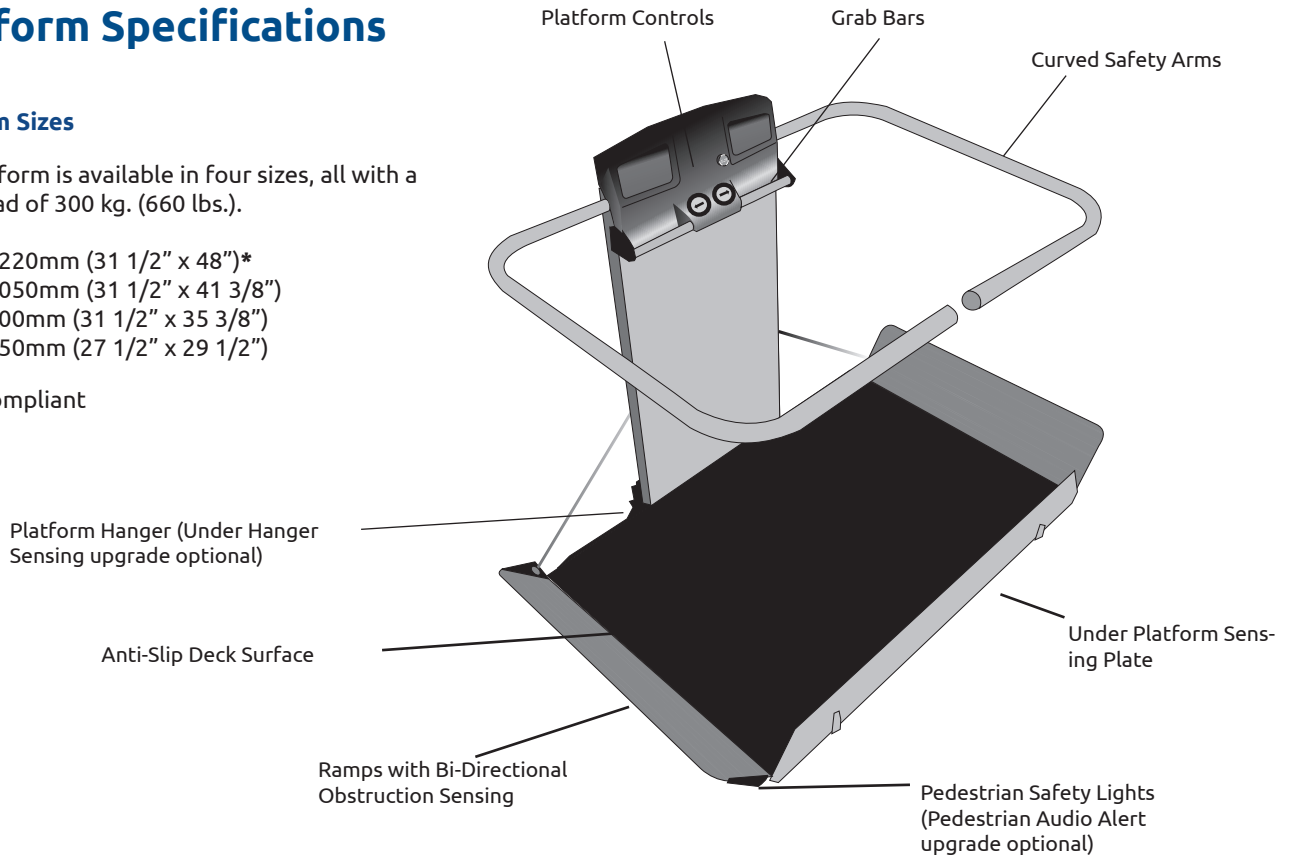

Platform Components

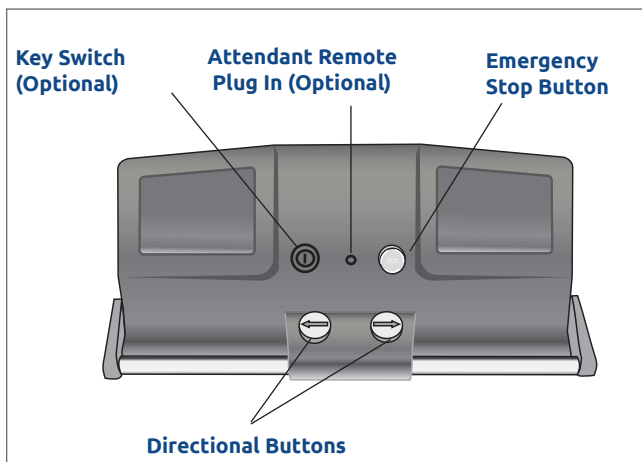

Platform Control Panel

The durable and vandal resistant platform control panel is mounted to the platform hanger. The standard platform controls are permanently mounted and consist of two large illuminated constant pressure **Directional Buttons** for independent operation and an **Emergency Stop Button** (with illumination optional).

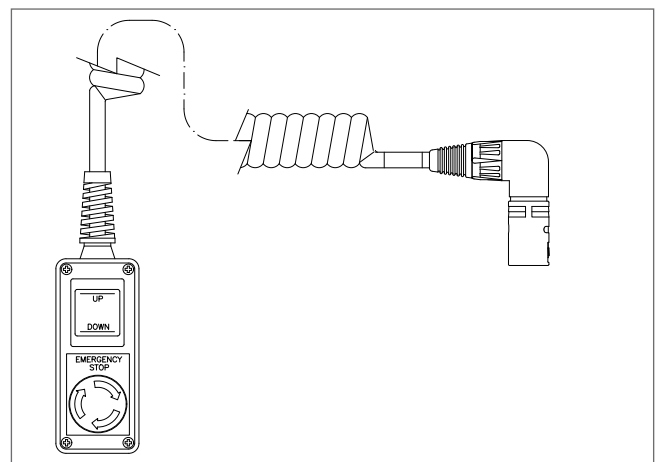

Optional Attendant Remote Control Unit

The platform can be equipped with an optional **Attendant Remote Control** that overrides the constant pressure **Directional Buttons** during attendant operation. The remote control unit can be removed when not required.

Standard Platform Features

Safety Sensing

The platform is equipped with safety sensors listed below. These sensors will automatically stop the lift when activated by 1.8 kg (4 lbs.) of pressure. The platform can then be backed away from the obstruction.

- **Leading Ramp Sensor**

When the platform is called to or from the landing area in the folded up position the leading ramp is sensitive to obstructions.

- **Bi-Directional Ramp Sensing**

The inside and outside surfaces of the leading ramp are obstruction sensitive in the direction of travel.

- **Under Platform Sensing Plate**

The under platform sensing plate detects obstacles underneath the platform.

Curved Safety Arms

Fully automatic 32mm (1 1/4") diameter Curved Safety Arms further increase the safety of the GSL Artira. They are directly over the perimeter of the platform, guarding the user. The top of the arm is located 948mm (37 3/8") above the platform deck. If arms should encounter an obstruction, they will retract to the up position upon release of the directional control button.

Emergency Stop Button

Located on the platform control panel, this large red button is used to stop the lift in an emergency.

Smooth Start & Stop

The Artira is equipped with a variable speed drive, programmed to automatically slow down while travelling through certain sections of the staircase. The platform is programmed to slow to 50% of the normal travel speed well in advance of corners and resumes full speed when the platform reaches straight sections. The lift controller is also programmed to slow the platform travel speed when approaching and departing landings.

Grab Bar

The Grab Bar is a 25mm (1") diameter aluminum bar located on the front face of the platform control panel to assist passengers in loading and unloading.

Pedestrian Safety Lights

This illuminated tube lighting located at the base of the ramps visually alerts pedestrians of the platform's location during travel, while still being discreet to the passenger.

Emergency Fold

In an emergency the platform can be manually folded and will lock in the folded position.

Optional Platform Features

Platform Lock

This lock secures the platform in its folded position protecting the unit from vandalism.

Under Hanger Obstruction Sensing

When the platform moves to or from the landing area in the folded up position, sensors on the underside of the hanger will automatically stop the lift when activated by a minimum of 1.8 kg (4 lbs.) of pressure.

Pedestrian Audio Alert

When the platform is folded up and traveling between stations, an audio chime on the platform is activated indicating the lift is in motion. The chime is deactivated when a passenger is using the lift.

Folding Seat

Designed for use by ambulatory passengers, this folding seat is equipped with a safety belt. For commercial applications, the folding seat and seat belt are required by the ASME A18.1 safety code in the USA.

Dek-Lite (requires folding seat)

Mounted below the folding seat, this light provides additional lighting to the platform.

Side Load

For confined lower landing spaces, an automatically deployed side load ramp allows the passenger to wheel onto the platform diagonally, offering easier access.

Auto Fold

This feature automatically folds the platform if it is left unfolded at a landing for a period of time.

Platform on Board Alarm

When the Emergency Stop Button is activated it illuminates and an alarm located on the platform. The alarm will alert others that the passenger on the lift requires assistance.

Attendant Remote Control

The Attendant Remote Control overrides the platform controls allowing an attendant to operate the lift.

Key Switch

To meet some local code requirements a key switch can be added to the platform control panel.

Side of Hanger Optical Sensing

Mounted on the side of the platform hanger, these sensors are designed to protect pedestrian traffic. This feature detects possible obstructions in open-core stairways and while the lift turns corners.

Note: In some jurisdictions certain optional features are either not permitted or mandatory depending on local codes. Please consult your local Garaventa representative for clarification.

Call Stations

Located at each landing, the call station enables the user to unfold the platform with a touch of a button. If the platform is not at the landing, the user simply presses the illuminated directional button to call the platform to their landing.

Garaventa Smart-Lite Technology™

The Artira's Smart-Lite Technology™ illuminates the correct call station button, guiding the user through the sequenced steps to call and unfold the lift from the call station (patent pending).

Call Station Options

- **Emergency Stop Button** (with illumination optional)
- **Attendant Call Switch**

Keyless (optional)

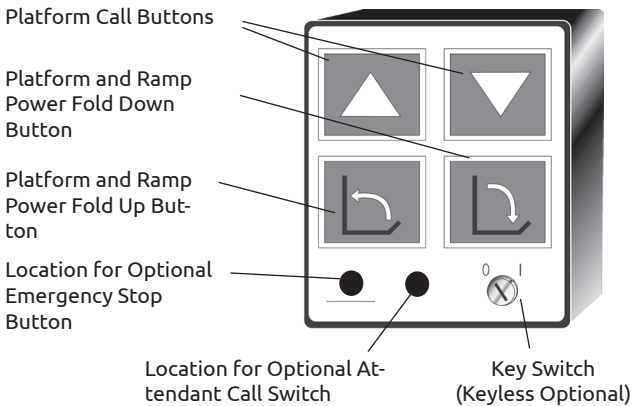

Call Station

A keyless call station is available as an option. The keyless lift does not have a keyswitch on the call station.

Remote Platform Fold/Call (optional)

This feature allows the platform to be folded up and called from any call station should the platform be left folded down.

Mounting Options

The call stations can be mounted on the wall (surface or flush mounted) or on a pedestal (when no suitable surface is available). The upper call station can also be mounted on the drive box or on the tube system itself (only available with Drive Box arrangement). Flush mount call stations can be pre-wired during the construction or building renovations, resulting in a cleaner appearance with no surface wiring.

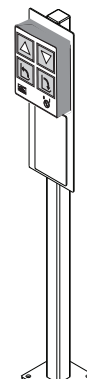

Freestanding Call Station Pedestal (optional)

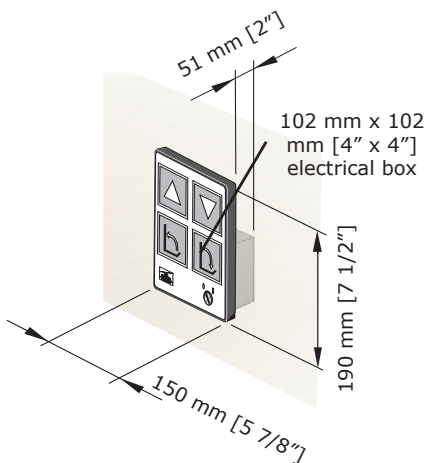

Flush Mount Call Station (optional)

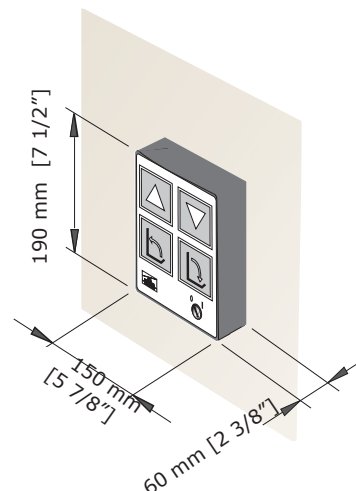

Surface Mount Call Station

Lower Landing Configuration Options

A variety of lower landing configurations are available to suit each stairway. If you have a unique arrangement, contact your local Garaventa representative or call the Garaventa Design Hot Line for more information.

Straight Lower Landing for Drive Box

This configuration is used when there is adequate space to load/unload straight onto the platform at the lower landing.

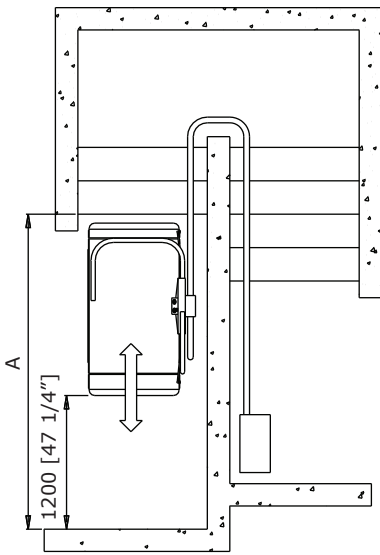

Straight Lower Landing

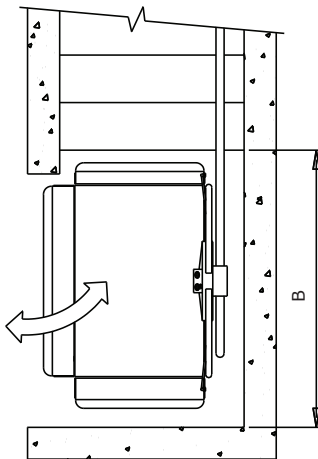

Straight Landing - With Side Load

Drop-Down Lower Landing

(Drive Box System Shown) When lower landing space is limited, the lower landing section of the tubes are angled downward at a 45° angle to land the platform as close to the bottom step as possible. This configuration is often combined with the side load feature.

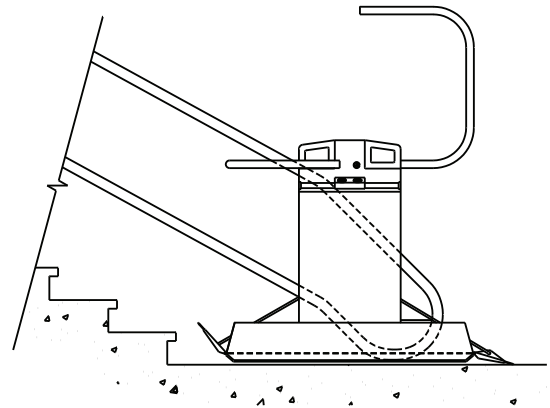

Straight Lower Landing for Compact Drive

The Rope Tensioning Device used with the Compact Drives requires a minimum clearance of 250mm (9 7/8”) from the end of the tubes to the nearest obstruction.

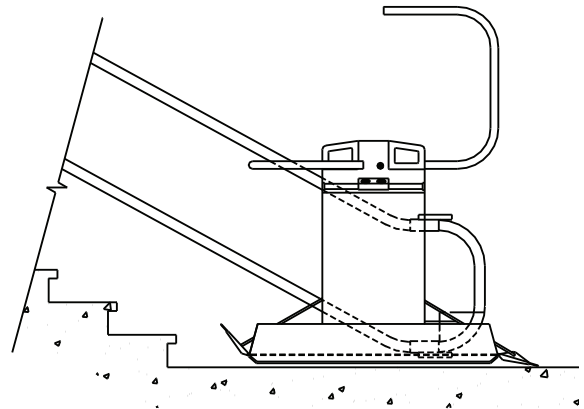

90° and 180° Lower Landings

These configurations place the platform away from pedestrian traffic while loading/unloading and storing the platform. Ideal for stairs with sufficient clearances such as stairways with alcoves, hallways or otherwise unused spaces under stairs.

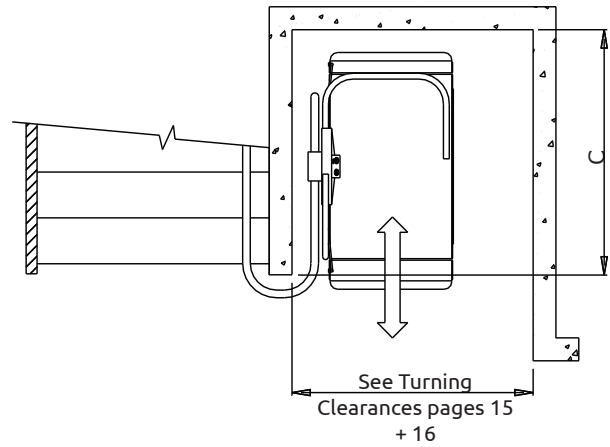
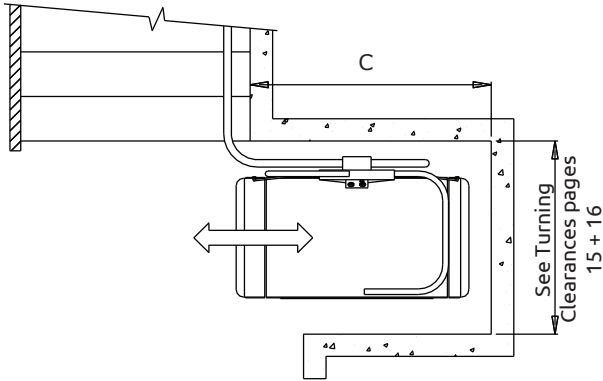

Required Lower Landing Clearances

Platform Size	Dim. A	Dim. B	Dim. C
800 x 1220 mm* (31 1/2" x 48")*	2883 (113 1/2)	1708 (67 1/4)	1540 (60 5/8)
800 x 1050 mm (31 1/2" x 41 3/8")	2713 (106 3/4)	1538 (60 1/2)	1370 (53 7/8)
800 x 900 mm (31 1/2" x 35 3/8")	2563 (100 7/8)	1388 (54 5/8)	1220 (48)
700 x 750 mm (27 1/2" x 29 1/2")	2368 (93 1/4)	1218 (48)	1070 (42 1/8)

Notes:

- *ADA Compliant
- Dimension A + B has been calculated using a drop-down landing configuration and a first riser height of 178mm (7").
- Dimensions are based on standard platforms with standard ramps. Ramp extensions will increase the clearances required.
- Contact your local Garaventa representative or call the Garaventa Design Hot Line for more information.

Landing Over a Flight

This enables the platform to be loaded/unloaded and stored over a flight of stairs that is not being serviced by the lift.

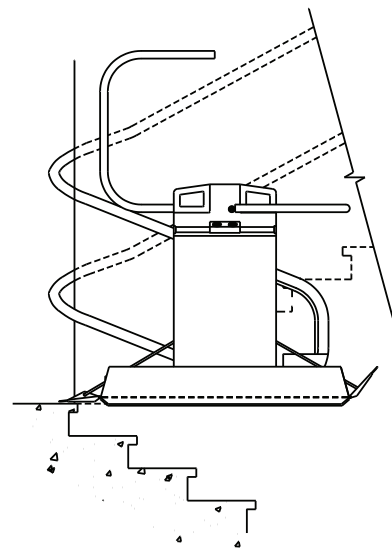

Required Turning Clearances

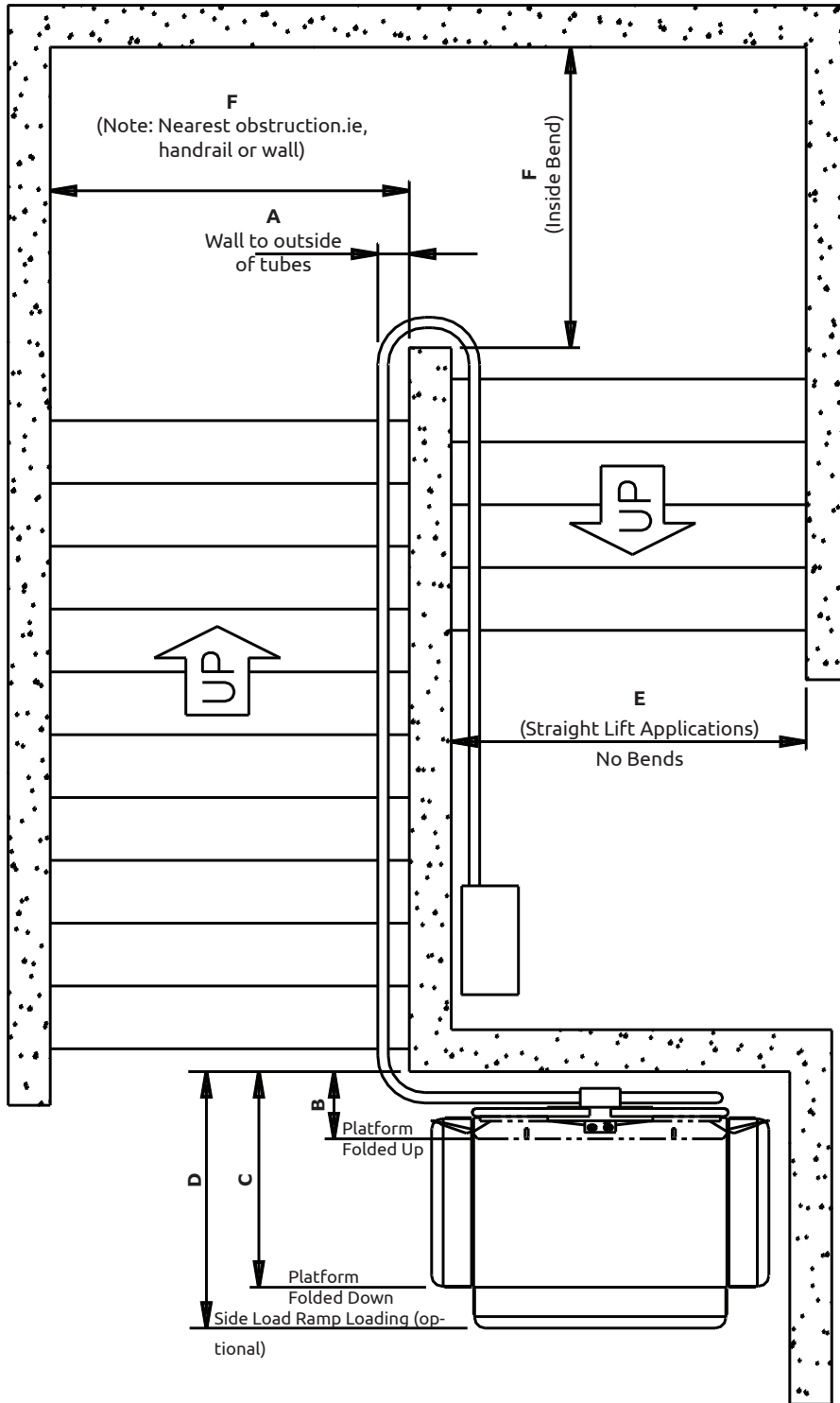

Stair Width Clearances and Platform Projection Dimensions

Turning Clearance Chart

The space requirements of the GSL Artira are affected by how the tube system is supported. The lift can either be mounted directly to the wall, **Direct Mount**, or structural support posts can be supplied **Tower mount**.

Dim.	Attachment Method	Platform Sizes							
		800 x 1220 mm* (31 1/2" x 48")*		800 x 1050 mm (31 1/2" x 41 3/8")		800 x 900 mm (31 1/2" x 35 3/8")		700 x 750 mm (27 1/2" x 29 1/2")	
		mm	in	mm	in	mm	in	mm	in
A	Direct Mount	125	4 7/8	125	4 7/8	125	4 7/8	125	4 7/8
	Tower Mount	150	5 7/8	150	5 7/8	150	5 7/8	150	5 7/8
B	Direct Mount	320	12 5/8	320	12 5/8	320	12 5/8	330	13
	Tower Mount	345	13 5/8	345	13 5/8	345	13 5/8	355	14
C	Direct Mount	1015	40	1015	40	1015	40	900	35 3/8
	Tower Mount	1040	41	1040	41	1040	41	925	36 3/8
D	Direct Mount	1230	48 3/8	1230	48 3/8	1230	48 3/8	1115	44
	Tower Mount	1255	49 3/8	1255	49 3/8	1255	49 3/8	1140	45
E	Direct Mount	1035	40 3/4	1035	40 3/4	1035	40 3/4	920	36 1/4
	Tower Mount	1060	41 3/4	1060	41 3/4	1060	41 3/4	945	37 1/4
F	Direct Mount	1225	48 1/4	1185	46 5/8	1145	45 1/8	1025	40 3/8
	Tower Mount	1250	49 1/4	1210	47 5/8	1170	46 1/8	1050	41 3/8

Notes:

- *ADA Compliant
- Dimensions E and F include 20mm (3/4") running clearance and include standard ramps. Ramp extensions will increase the clearances required. Contact your local Garaventa Lift representative or call the Garaventa Design Hot Line for more information.
- For towers mounted to 2" x 6" wood boards on walls (see page 26) add 38mm (1 1/2") to the above tower mount dimensions.

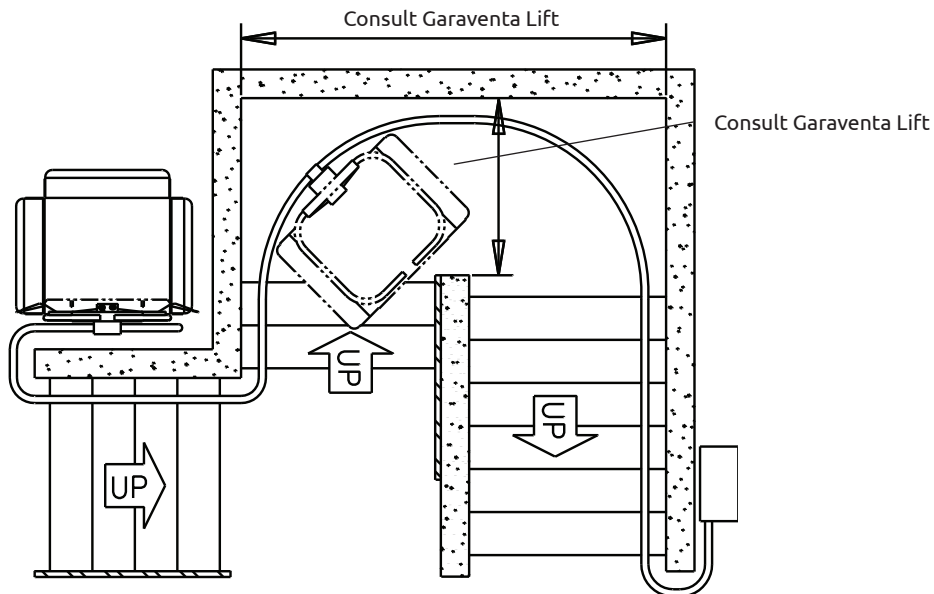

Consult Garaventa Lift for Clearances of Outside Radius Bends

Standard Upper Landing Drive Configurations

A variety of configurations are available for each drive system. If you have a unique or complex application that is not covered in this guide, contact your local Garaventa Lift representative or call the Garaventa Design Hot Line for more information.

Standard In-Line Drive

The standard in-line drive configuration places the drive 1200mm (47 1/4") from the top of the stairs to allow a passenger to load and unload the platform and maneuver past the drive box.

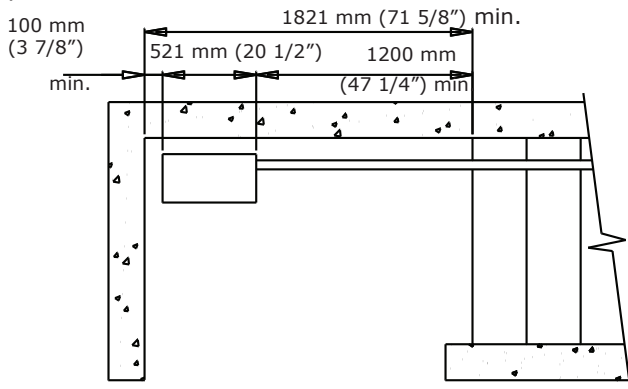

90° & 180° Drive

The 90° or 180° configuration allows the drive box to be located away from the top of the stairs and pedestrian traffic.

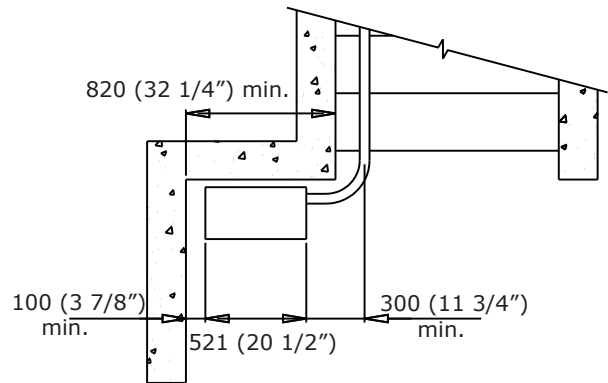

Offset Drive

When upper landing space is limited, the drive box can be positioned closer to the stairs and to the wall.

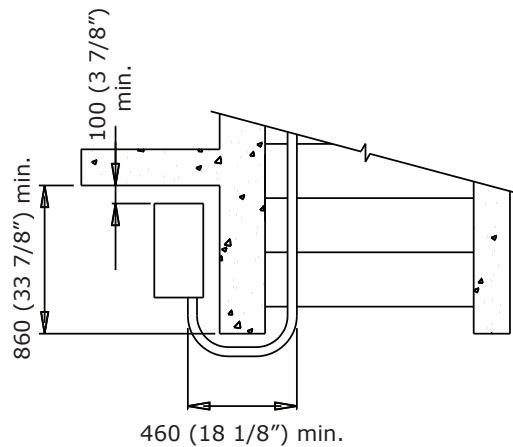
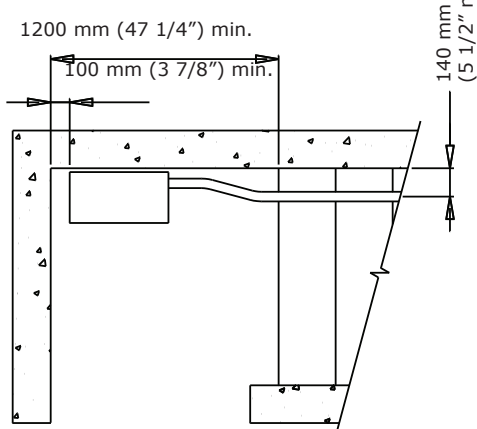

Notes:

For 90° and 180° configurations, add 200mm (7 7/8") if the Call Station is mounted on the tubes.

Compact Drive

The Compact Drive is designed to utilize a minimum amount of space, in some conditions as little as 203mm (8"). Required clearances vary with stair angle, motor orientation, as well as ramp and platform sizes. For further details on this drive system refer to page 20, and for lower landing considerations see pages 13 and 14.

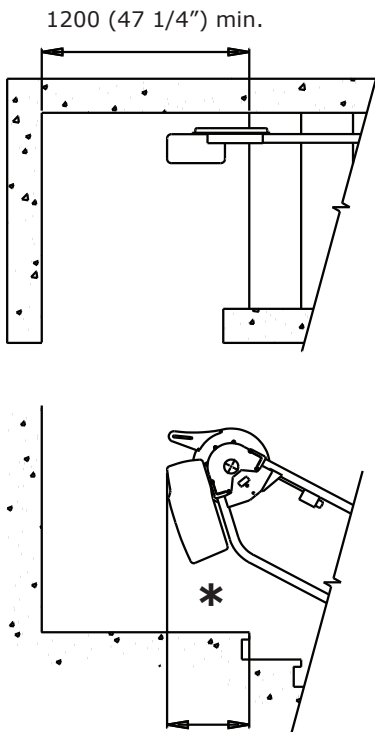

*152mm (6") - 406mm (16")
Dimension variable with stair angle, motor orientation, ramp extensions and platform size.

Reverse Drive

By reversing the drive box it can be placed closer to the top stair nose, while still maintaining sufficient clearance for loading and unloading. This scenario is ideal for landings between stairs or where walls end at the top of the stairs.

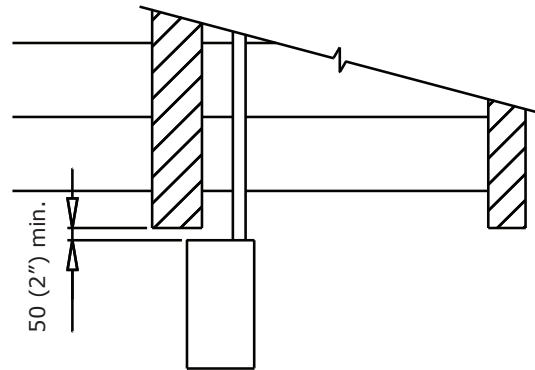

Alternate Drive Configurations

Drive on Treads - Flight Beyond Upper Landing

Designed for intermediate landings with restricted clearances due to narrow hallways, the drive box is mounted on the stair treads. This ensures maximum clearance on the landing for pedestrian traffic.

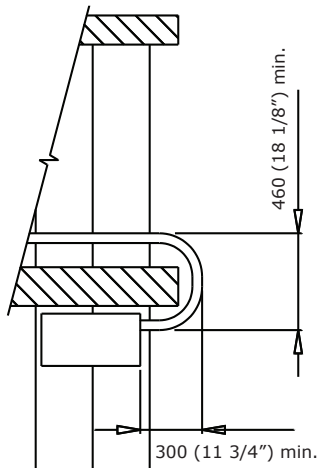

Drive Through Wall at 90° or 180°

The tubes go through the wall enabling the drive to be stored in a separate room instead of on the upper landing.

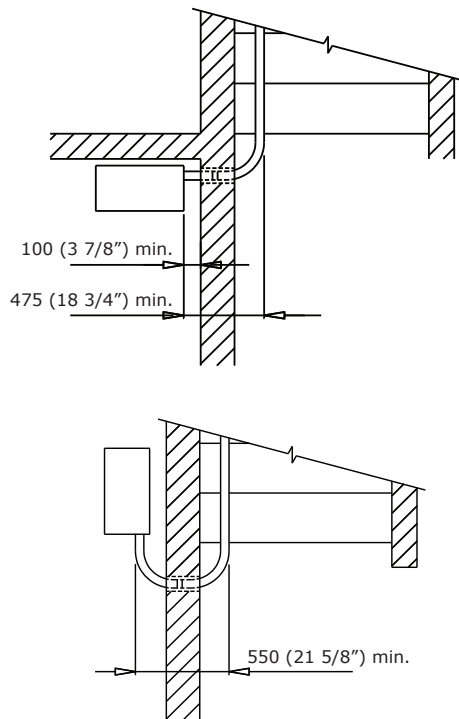

Drive Under Floor

The drive box can be positioned under the floor if sufficient clearances are available. It can be placed on its side or right side up.

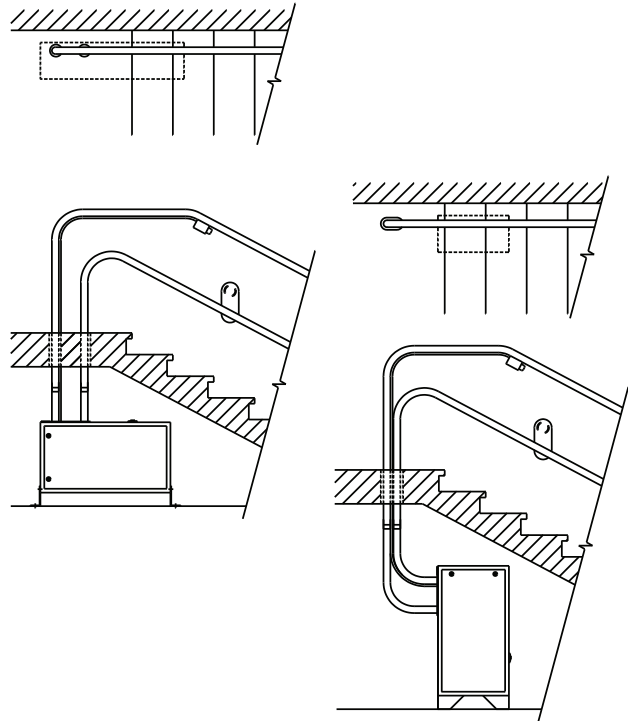

Drive on Shelf

The drive box can be attached to a shelf that is fastened to a solid wall.

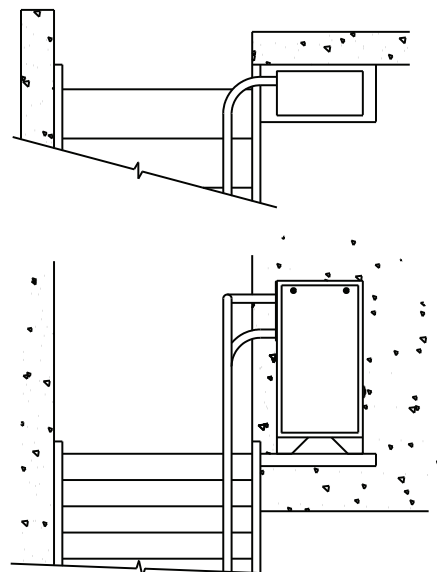

Drive System

The drive is always located at the upper end of the guide tubes. It is available in two arrangements, the standard **Drive Box** and the **Compact Drive**. Each drive system is suited to a particular application, with a variety of design configurations to choose from (see pages 17-19 for drive configurations).

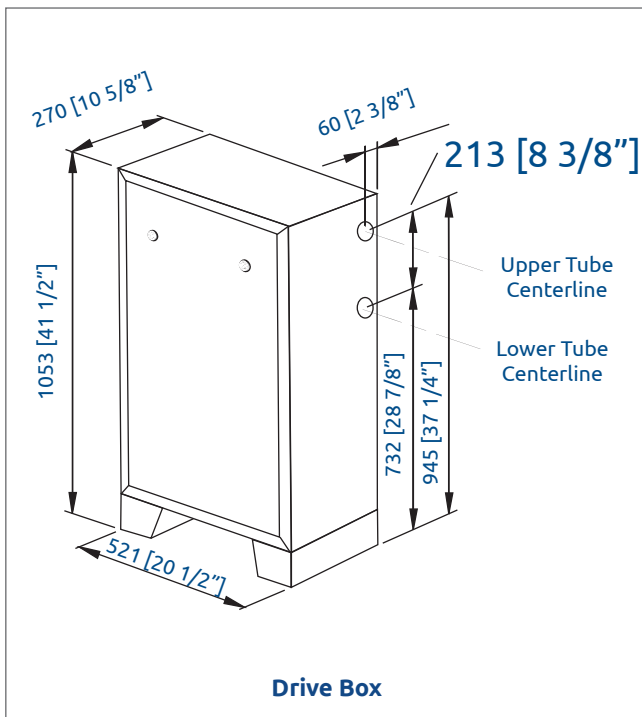

Drive Box

The **most common** drive arrangement, the Drive Box, uses a **2 H.P. motor** and is always mounted at the upper end of the guide tubes. In some cases, a **3.6 H.P. motor** is used instead, depending on the travel length and number of tube bends.

The drive box has a **multitude of design configurations** (including under the floor and through the wall).

Mains Power Requirements

Both drive systems require 208-240 VAC single-phase 50/60 Hz. on a dedicated 20 amp. circuit.

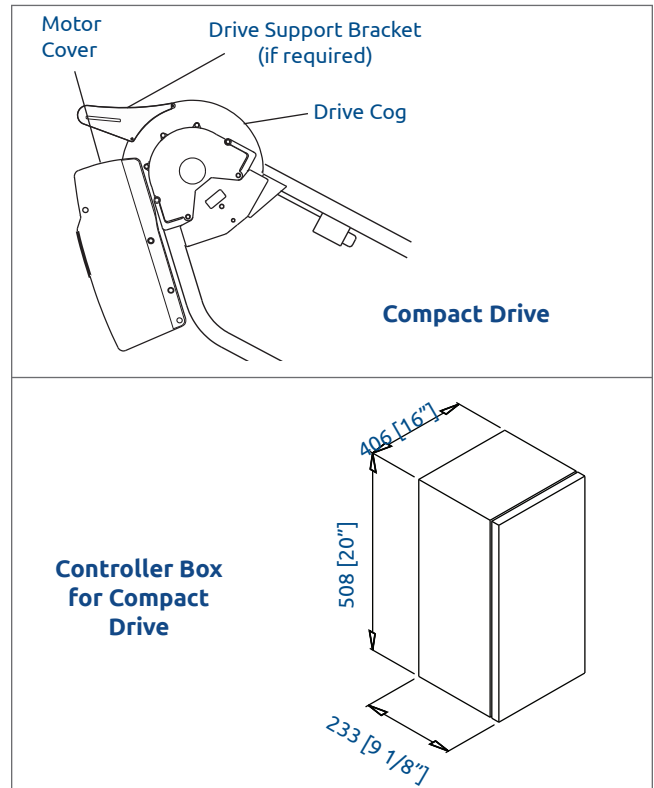

Compact Drive

The compact drive is ideal for lifts with **restricted upper landings**. It utilizes the same components as the Drive Box however, they are arranged differently. The drive cog and the motor are directly attached to the upper end of the guide tube system, with the electrical components housed in a **Controller Box** that can be **located up to 6 meters (20ft) away from the compact drive**.

The compact drive is not available outdoors or with stainless steel tubes.

Additional Component Options

The GSL Artira can be equipped with a number of additional safety features:

Audio Visual Alert

A wall mounted strobe light and audible chime cautions pedestrians in the vicinity that the lift is in operation. The volume of the audible chime can be adjusted. This option is ideal for stairways with 90 degree or 180 degree switchbacks.



Outdoor and Extreme Applications

When located outdoors or in extremely harsh environmental conditions, the lift will require a stainless steel drive box, stainless steel tubes, towers and audio visual alerts (if specified). A vinyl platform cover is recommended for outdoor applications. The Compact Drive System is not available for outdoor applications or with stainless steel tubes.



Vinyl Platform Cover

Notes:

In certain indoor applications such as near a swimming pool, an outdoor weather-resistant package may be required.

UPS Auxiliary Power Option (3000 VA)

If you select this option, an Uninterruptible Power Supply (UPS) will be provided with the lift. This optional feature enables the lift to operate normally during a power outage. Note that the UPS is installed in a secure enclosure.

- The UPS can be installed up to 4.5 meters (15 feet) from the drive system.
- Enclosure dimensions: 600 mm (23.6") high × 600 mm (23.6") wide × 300 mm (11.8") deep.
- This option requires a disconnect switch with an auxiliary contact.
- This option is allowed for indoor lifts only.



Fire Alarm Integration (Fire Service)

The fire service feature is designed to interface with a building's fire safety system and interrupt power to the lift when the fire alarm sounds. This **ensures the lift will not obstruct stairway traffic during evacuation**. If the lift is in use when the alarm sounds, the lift will only allow the platform to travel to the designated landing with the emergency exit. The passenger must use the constant pressure direction button. Custom versions of this feature are available. Consult Garaventa Lift.

Guide Tubes

The platform travels on two steel tubes, 51mm (2") in diameter, that are affixed 600mm (23 5/8") apart vertically. The location of the tubes on the stairs depends on the platform size and the angle of the stairs. Generally speaking, the lower tube is approximately 500mm (21 5/8") vertically above the stairs when a 800 x 1220 mm (31 1/2" x 48") platform is used.

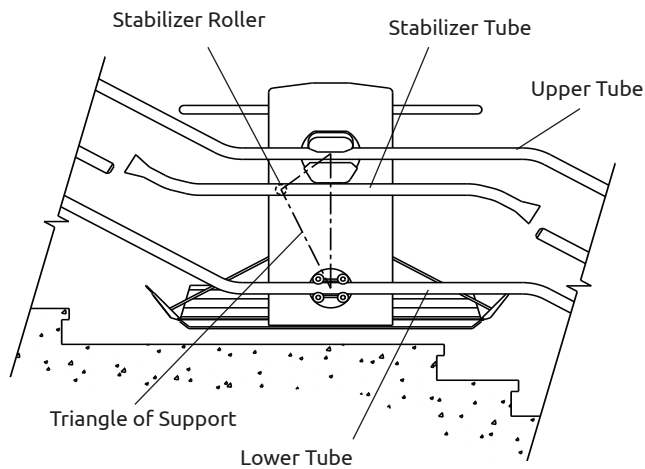

Horizontal Stabilizer

(back of platform shown)

Stabilizer

The stabilizer tube is placed in horizontal or shallow sections of the lift's travel. This slotted tube allows a roller, mounted to the back of the platform, to enter and travel through. This roller connection creates a triangle of support to stabilize the platform. The stabilizer is required whenever the lift travels horizontally or at an angle of less than 20°.

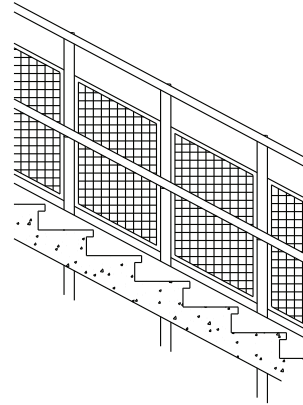

Infill Panels (Optional)

These mesh screens are located between the towers of the lift to create a safety barrier.

As an alternative, attachment angles can be welded to the sides of the towers to allow for infill panels of other materials, such as Plexiglas or wood (infill panel material is not supplied by Garaventa Lift).

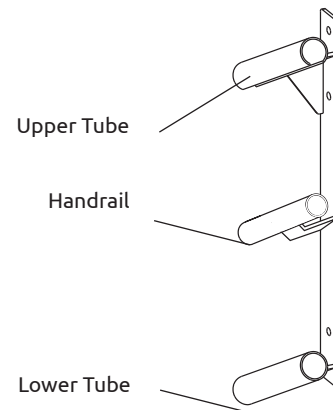

Pedestrian Handrails (Optional)

With the installation of the tube system the existing handrails are often obstructed or removed. A third tube, 38mm (1 1/2") in diameter, can be located between the main guide tubes to serve as a pedestrian handrail. In most applications this handrail can be positioned within the accepted code height range. **Due to interference with the platform during travel, full building code compliance may not be possible.** Some restrictions apply when used in conjunction with the horizontal stabilizer (see above for further details on the stabilizer). Contact your local Garaventa Lift representative or call the Garaventa Lift Design Hot Line for more information.

Platform Storage at Upper Landing (Optional)

This feature allows the platform to travel along the tubes, while folded, to a storage location off the stairs. A stabilizer tube is required for this application (see page 22 for stabilizer details). Other configurations are possible.

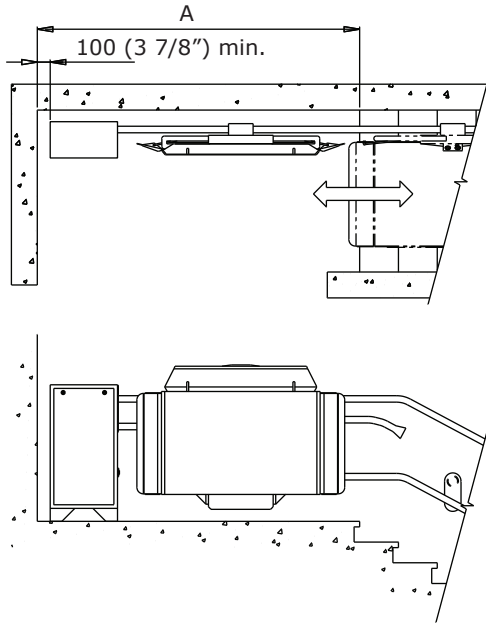

In-line Drive with Platform Storage
(Drive Box Shown, also available with Compact Drive)

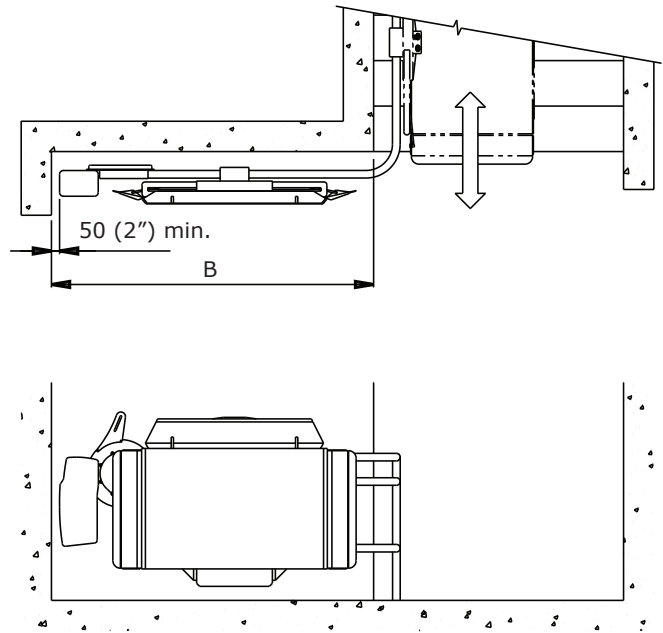

90° Drive with Platform Storage
(Compact Drive Shown, also available with Drive Box)

Dim.	Drive Arrangement	Platform Size							
		800 x 1220 mm (31 1/2" x 48")		800 x 1050 mm (31 1/2" x 41 3/8")		800 x 900 mm (31 1/2" x 35 3/8")		700 x 750 mm (27 1/2" x 29 1/2")	
		mm	in	mm	in	mm	in	mm	in
A.	Drive Box	2350	92 1/2	2175	85 5/8	2020	79 1/2	1880	74
	Compact Drive	2035	80 1/8	1865	73 3/8	1715	67 1/2	1565	61 5/8
B.	Drive Box	2245	88 3/8	2075	81 3/4	1925	75 3/4	1775	69 7/8
	Compact Drive	1935	76 1/8	1765	69 1/2	1615	63 5/8	1465	57 5/8

Notes:

Dimensions for Compact Drives are approximate only. Factors affecting the location of the Compact Drive include stair angle, motor orientation and ramp extensions. Contact your local Garaventa Lift representative or call the Garaventa Lift Design Hot Line for more information.

- If the call station is mounted on the tubes, add 200mm (7 7/8") for drive box configurations.
- Dimensions are based on standard platforms with standard ramps. Ramp extensions will increase the clearance dimensions required.

Platform Running Clearances Required For Platform Folded Up

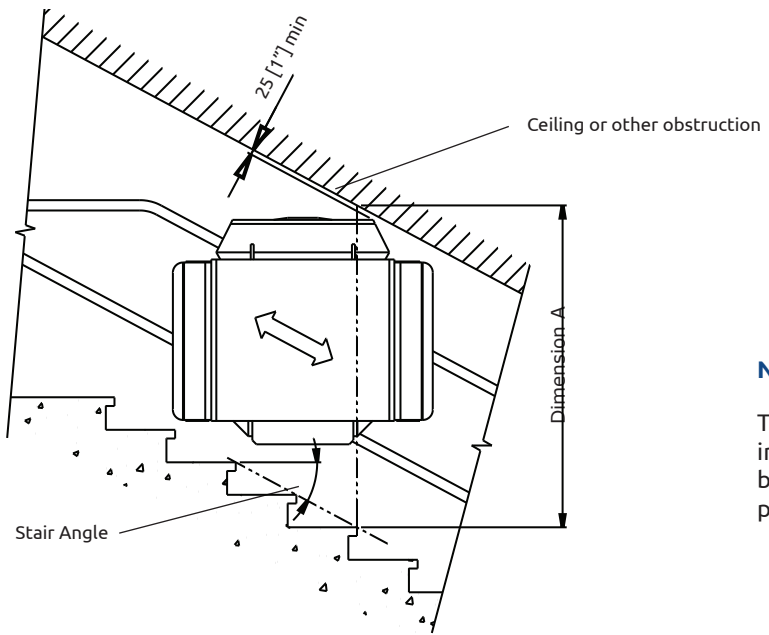

Note:

This running clearance is for the platform in the folded position only. See dimensions below for overhead requirements for passenger usage and codes.

Minimum Overhead Clearances To Meet Code Requirements

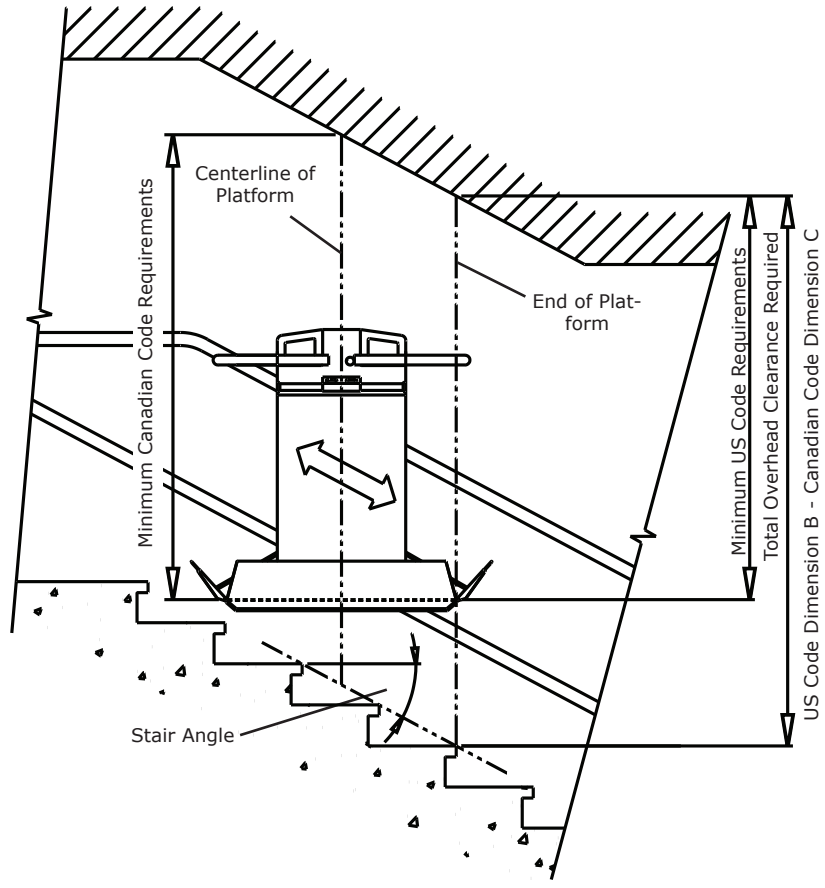

Minimum Code Requirements:

US Code (ASME A18.1)

1524mm (60") overhead clearance required to any point above the platform deck. Refer to Dimension B in chart on page 25.

Canadian Code (CSA B355)

1500mm (59") overhead clearance required to the centerline of the platform. Refer to Dimension C in chart on page 25.

Important Note: Please consult the local Garaventa Lift representative for local code requirements.

Platform Running Clearances Required For Platform Folded Up

Dimension A

Stair Angle	Platform Size							
	800 x 1220 mm (31 1/2" x 48")		800 x 1050 mm (31 1/2" x 41 3/8")		800 x 900 mm (31 1/2" x 35 3/8")		700 x 750 mm (27 1/2" x 29 1/2")	
	mm	in	mm	in	mm	in	mm	in
22°	1560	61 3/8	1500	59	1445	56 7/8	1330	52 3/8
25°	1690	66 1/2	1610	63 3/8	1540	60 5/8	1400	55 1/8
30°	1825	71 7/8	1730	68 1/8	1645	64 3/4	1475	58 1/8
35°	2000	78 3/4	1880	74	1775	69 7/8	1560	61 3/8
40°	2215	87 1/4	2070	81 1/2	1945	76 5/8	1685	66 3/8
45°	2460	96 7/8	2290	90 1/8	2140	84 1/4	1845	72 5/8

Clearances to Meet US Code Requirements (ASME A18.1)

Dimension B

Stair Angle	Platform Size							
	800 x 1220 mm (31 1/2" x 48")		800 x 1050 mm (31 1/2" x 41 3/8")		800 x 900 mm (31 1/2" x 35 3/8")		700 x 750 mm (27 1/2" x 29 1/2")	
	mm	in	mm	in	mm	in	mm	in
22°	2086	82 1/8	2020	79 1/2	1960	77 1/8	1880	74
25°	2170	85 3/8	2090	82 1/2	2020	79 1/2	1930	76
30°	2320	91 3/8	2220	87 1/2	2135	84	2020	79 1/2
35°	2480	97 5/8	2365	93 1/8	2260	89	2120	83 1/2
40°	2665	104 7/8	2525	99 3/8	2400	94 1/2	2235	88
45°	2880	113 3/8	2710	106 3/4	2560	100 3/4	2365	93

Clearances to Meet Canadian Code Requirements (CSA B355)

Dimension C

Stair Angle	Platform Size							
	800 x 1220 mm (31 1/2" x 48")		800 x 1050 mm (31 1/2" x 41 3/8")		800 x 900 mm (31 1/2" x 35 3/8")		700 x 750 mm (27 1/2" x 29 1/2")	
	mm	in	mm	in	mm	in	mm	in
22°	1820	71 5/8	1785	70 1/4	1755	69 1/8	1705	67 1/8
25°	1865	73 3/8	1825	72	1790	70 1/2	1730	68
30°	1945	76 5/8	1895	74 5/8	1850	72 7/8	1780	70
35°	2030	79 7/8	1970	77 1/2	1920	75 5/8	1835	72 1/4
40°	2130	83 7/8	2060	81 1/8	1995	78 1/2	1895	74 5/8
45°	2245	88 3/8	2160	85	2085	82 1/8	1965	77 3/8

Attachment Methods

The following are examples of common tube attachment methods. To ensure that the structure can withstand the loads and forces exerted by the lift, please consult a structural engineer.

Tube Attachments

To maintain the vertical separation between the tubes, distance struts and gussets are welded to the tubes. The struts are attached either directly to the wall or to square or rectangular steel support towers.

Please refer to the loading diagram on page 29 for wall and floor reactions.

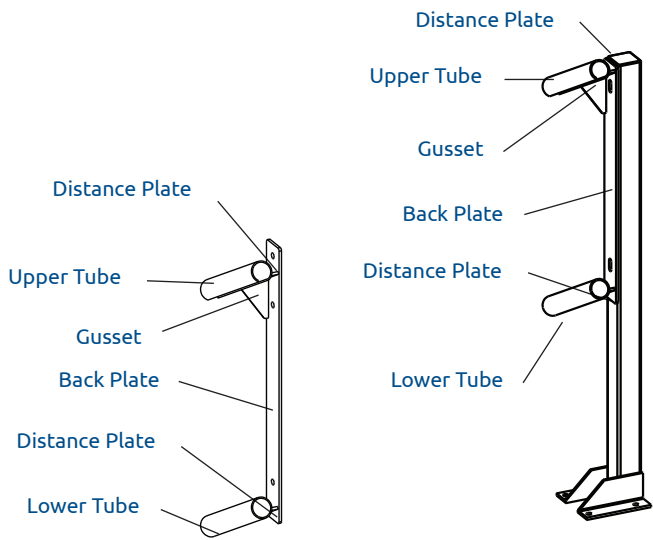

Direct Mount Strut

Tower Mount Strut

Solid Walls

Solid concrete, concrete block, wood or steel reinforcement. This construction is ideal for direct mounting as the struts can be attached directly to the wall. Where extra support is necessary the upper hole in the strut can be fastened through the wall.

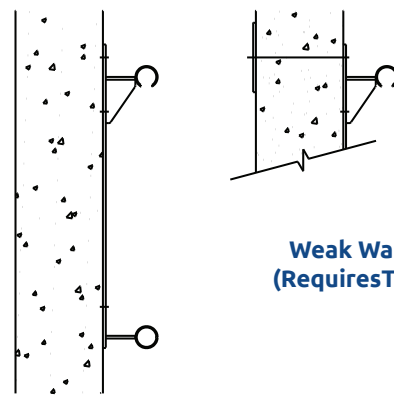

Direct Mount

Weak Wall Structure (Requires Through Bolt)

Wood Stud Walls

These structures require support towers, along with a 2" x 6" board that is screwed to the studs in the wall, running parallel to the stair flight. The towers must be attached to the board as well as to the floor or stair treads.

When using this attachment method, add the board thickness of 38mm (1 1/2") to the turning clearances shown on pages 15 & 16.

Note: Never attach a lift to a wall framed with steel studs.

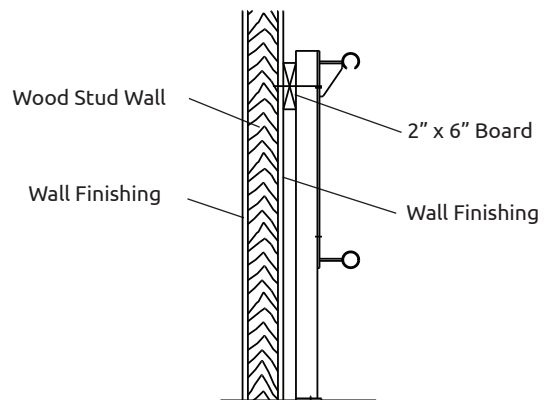

Tower Mount to 2" x 6" Board on Wall

Freestanding Support Towers

Solid concrete stairs, steel pan stairs filled with concrete, 76mm (3") thick wood stairs/landings. These are required when there are no existing support walls, or when the lift is required to be freestanding.

For concrete-filled steel pan treads, the towers are either bolted through the treads (where access is possible) or attached to a steel stringer for additional support.

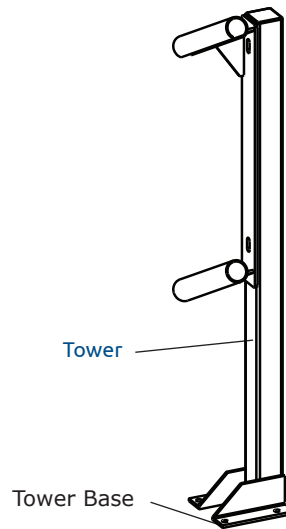

Freestanding Tower Mount

Please refer to the loading diagram on page 29 for wall and floor reactions.

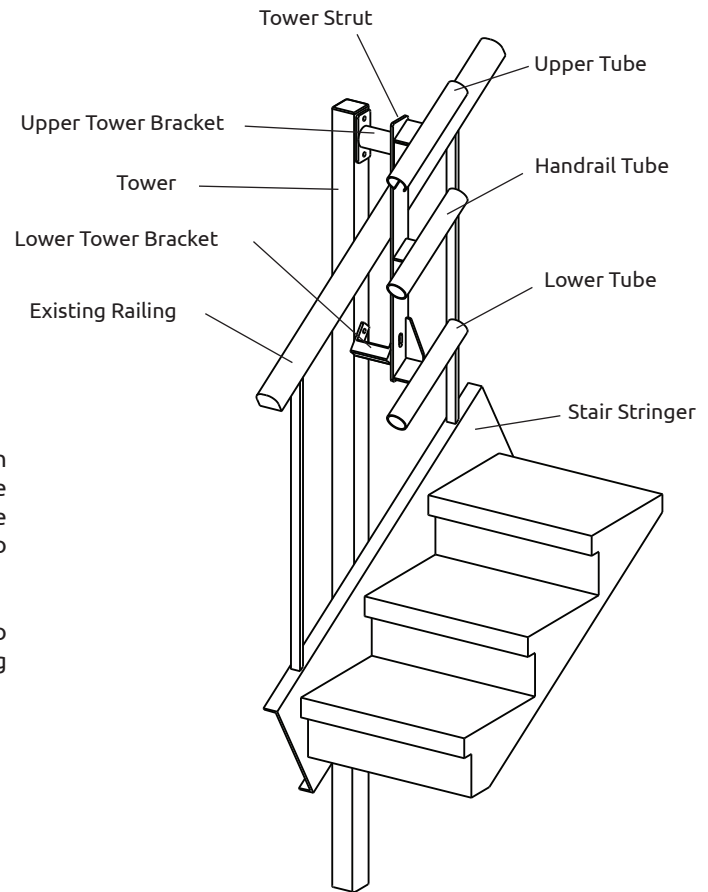

Tower Mount in Open Balustrade

Open Balustrade - Towers In The Core

Towers can be positioned within the open stair core when there is insufficient platform turning clearances or if the stairs are too weak for freestanding towers. The towers are fastened to the walls, stringers, or stair edge, as well as to the floors.

Handrails can be removed or special brackets can be used to allow for tube attachment to the towers, without damaging the balustrade.

Wall Height Requirements for Direct Mounting

For prevention of concrete breakout, these required wall heights include 100mm (3 7/8") of clearance from the top hole of the strut to the top of a concrete wall.

Stair Angle	Platform Size							
	800 x 1220 mm (31 1/2" x 48")		800 x 1050 mm (31 1/2" x 41 3/8")		800 x 900 mm (31 1/2 x 35 3/8")		700 x 750 mm (27 1/2" x 29 1/2")	
	mm	in	mm	in	mm	in	mm	in
20°	1155	45 1/2	1125	44 1/4	1095	43 1/8	1055	41 1/2
25°	1230	48 3/8	1190	46 7/8	1155	45 1/2	1100	43 1/4
30°	1315	51 3/4	1270	50	1225	48 1/4	1155	45 1/2
35°	1410	55 1/2	1355	53 3/8	1300	51 1/8	1215	47 7/8
40°	1520	59 7/8	1450	57 1/8	1385	54 1/2	1285	50 5/8
45°	1645	64 3/4	1560	61 3/8	1485	58 1/2	1365	53 3/4

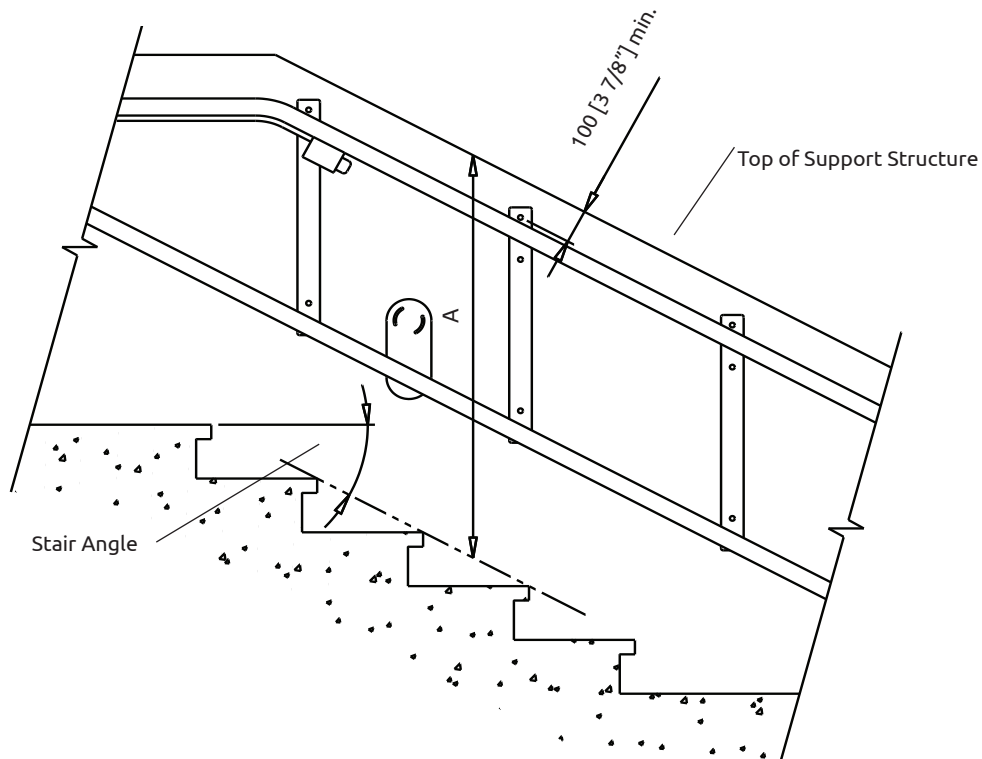

Minimum Support Structure Height for Direct Mounting on Concrete Wall

Loading Diagram

Loads are based on an 800 x 1220mm (31 1/2" x 48") platform:

Straight Lifts And/Or Lifts With Inside Radius Bends

F1= 1093 N (246 lbf)
F2= 2942 N (661 lbf)
d1= 296mm (11 5/8")
d2= 506mm (19 7/8")

Moment At The Center Of Tower Or Back Of Direct Mount Strut

M= $F \times d$ (F: Force; d: distance)
M= $F1 \times (d1 + X) + F2 \times (d2 + X)$

Tower Mount

X is 92mm (3 5/8") min. to 330mm (13") max.

Direct Mount

X is 100mm (4.0") min. to 140mm (5 1/2") max.

Maximum Moment

M= 3144 Nm (27827 in.lbf) with Tower Mount
M= 2377 Nm (21041 in.lbf) with Direct Mount

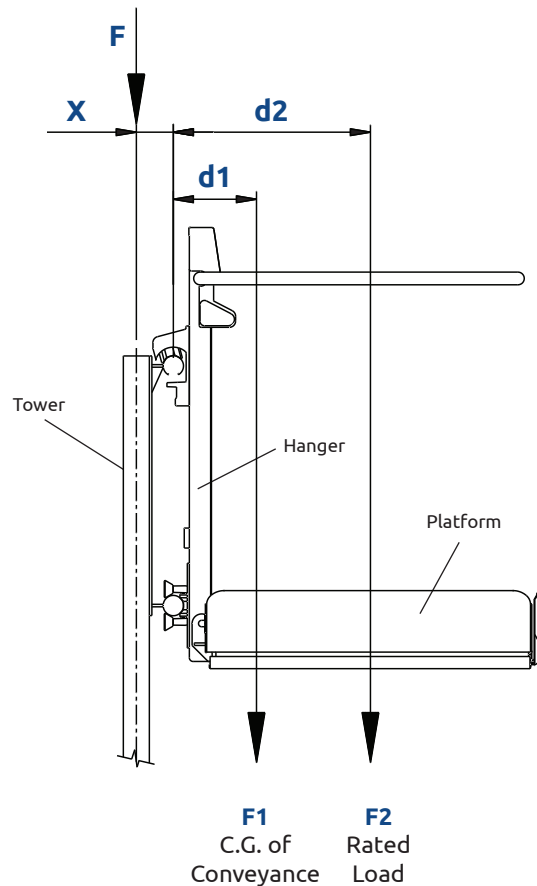

Lifts With Outside Radius Bends

F1= 1231 N (277 lbf)
F2= 2942 N (661 lbf)
d1= 341mm (13 3/8")
d2= 606mm (23 7/8")

Moment At The Center Of Tower Or Back Of Direct Mount Strut

M= $F \times d$ (F: Force; d: distance)
M= $F1 \times (d1 + X) + F2 \times (d2 + X)$

Tower Mount

X is 92mm (3 5/8") min. to 330mm (13") max.

Direct Mount

X is 100mm (4.0") min. to 140mm (5 1/2") max.

Maximum Moment

M= 3580 Nm (31682 in.lbf) with Tower Mount
M= 2787 Nm (24664 in.lbf) with Direct Mount

Technical Reference of Standard Features

Platform Sizes

800 x 1220mm (31 1/2" x 48") - ADA Compliant
800 x 1050mm (31 1/2" x 41 3/8")
800 x 900mm (31 1/2" x 35 3/8")
700 x 750mm (27 1/2" x 29 1/2")

Curved Safety Arms

Fully automatic, 32mm (1 1/4") diameter safety arms, top of arm 948mm (37 3/8") above platform deck.

Pedestrian Safety Lights

Illuminated tube lighting, located at both ends of the platform deck. Alerts pedestrians that the platform is in motion.

Rated Load

300 kg. (660 lbs.)

Speed

6 meters (20 ft) per minute, slowing to 3 meters (10 ft) through corners and when approaching or departing landings.

Operating Controls

Call Stations (Standard): Equipped with Garaventa Lift Smart-Lite Technology™, constant pressure directional buttons, one touch fold & unfold buttons, 24VDC power, and keyed operation.

Platform (Standard): Equipped with constant pressure switches, Emergency Stop Button (manual reset) and key-less operation

Drive System

Motor: Single phase (supplied by inverter) 2 H.P. drive box at the end of the guide tube system. The drive box can be located away from the upper landing by extending the guide tubes.

Power Requirements: The mains power requirement for both drive systems is 208-240 VAC, 50/60 HZ single phase on a dedicated 20 amp. circuit.

Power Transmission: Roped sprocket using 8mm (3/8") wire haul rope.

Emergency Use: Ratchet wrench (or handwheel) is provided.

Daily Cycles:

Your Artira is designed based on the following daily cycles:

- Normal 10
- Heavy 30
- Excessive 45
- Max. starts per hour 5

Consult your Sales Representative if there is a chance you may exceed these amounts.

Overspeed Safety

Located at the bottom of the tube assembly containing mechanical overspeed sensor and brake, with electrical drive cut-out protection.

Rail System

Two 51mm (2") O.D. steel tubes spaced 600mm (23 5/8") apart vertically.

Finishes

Durable electrostatically applied and baked fine textured Satin Grey paint.

Typical Wiring Layout

Actual wiring and number of conductors may vary depending on options, quantity of stations and lift configuration.

Some of the options that will affect the wiring include:

- Emergency Stop switches (requires 2 additional conductors to each call station)
- Additional Audio Visual Alerts (requires 3 additional conductors to each A/V)

The following options require field wiring by others:

- Attendant Call
- Fire Service
- Auxiliary Power System
- and possibly others

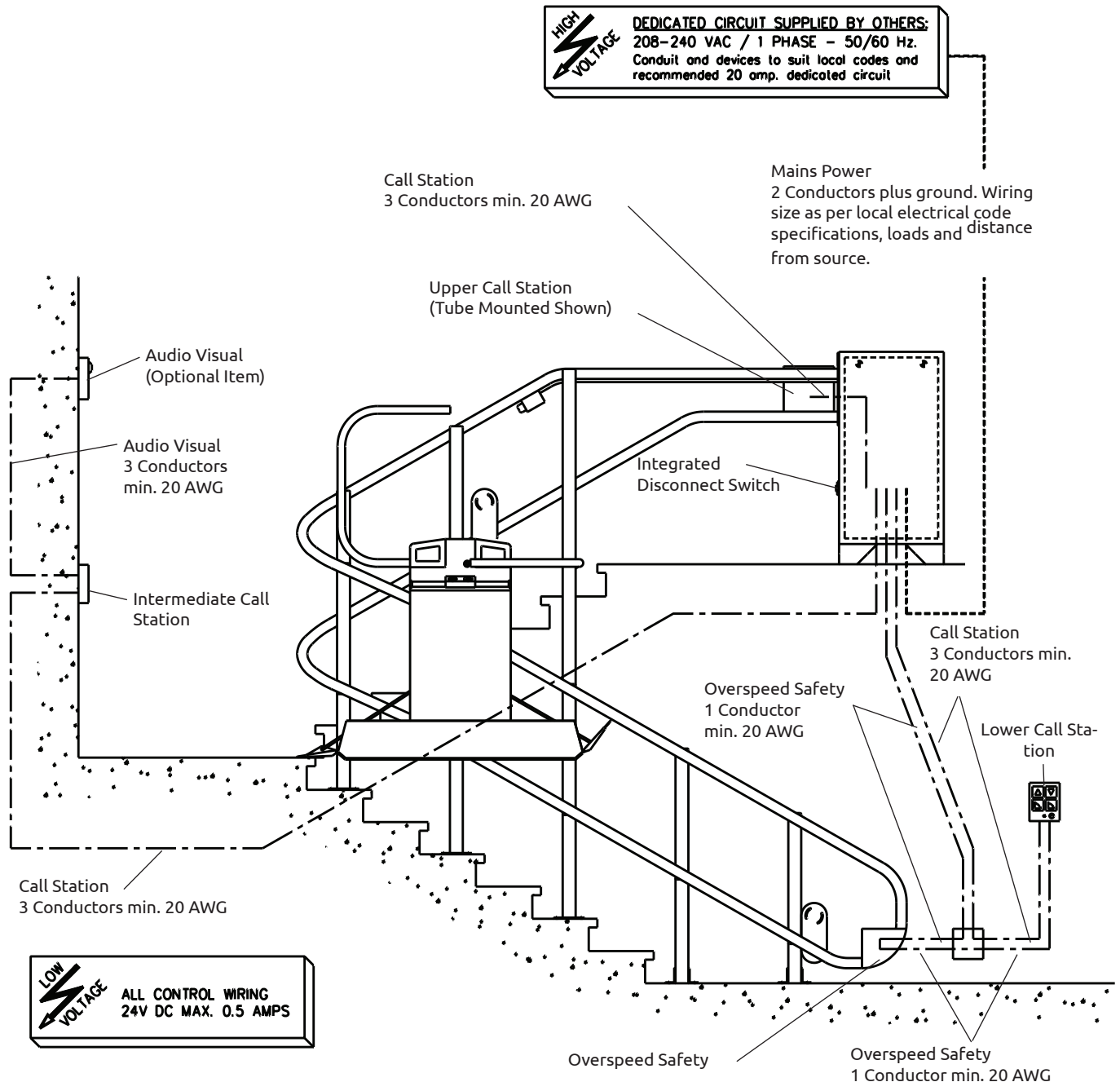



Garaventa Lift

T 800 663 6556 (toll free North America)

E info@garaventlift.com · **I** www.garaventlift.com

Authorized Garaventa Lift Representative

© Garaventa Lift. As we are continuously improving our products, specifications outlined in this brochure are subject to change without notice.

15810-T-DP-EN