

X3

DESIGN AND PLANNING GUIDE



Inclined Platform Lift For Straight Stairways

Please note:

Dimensions provided in this Guide are for **REFERENCE ONLY** and should not be used for site preparation or construction.

X3

Table of Contents

What is an Inclined Platform Lift?	4
How it Works	4
Finishes	5
Standard Color	5
Optional Color	5
Platforms	5
Platform Controls	5
Standard Platform Features	6
Emergency Stop Button	6
Over-speed Safety	6
Leading Ramp Sensor	6
Under Platform Sensing Plate	6
Platform Grab Bar	6
Emergency Fold	6
Curved Safety Arms	6
Hour Counter	6
Keyless Platform	6
Manual Emergency Lowering	6
Optional Platform Features	6
Folding Seat Assembly	6
Side Load (Standard on Commercial Lifts).....	6
On Board Alarm with Illuminated E-Stop Button	6
Keyed Platform	6
Platform Lock (Manual Platform) / Solenoid Lock (Automatic Platform)	6
Attendant Remote Control	6
Platform Power Fold and Unfold	6
Call Stations – Wireless (optional)	7
Keyless Call Stations (adjustable in field)	7
Mounting Options	7
Minimum Site Dimension Requirements	8
Attachment Methods	9-10
Overhead Clearances	11 - 12
Wall Height Requirements for Direct Mounting	13
X3 Loading Diagram	14
Technical Reference	15

What is an Inclined Platform Lift?

An inclined platform lift easily transports a passenger in a wheelchair, or someone who has difficulty using stairs. The lift can be operated independently or by an attendant with an attendant remote control (optional item). Compatible for indoor and outdoor applications, the **Garaventa Inclined Platform Lift** is a versatile, attractive and cost-effective accessibility solution.

Why an X3?

No Building Renovations (Modifications)

Inclined platform lifts fit easily into most stairways and do not require specially constructed hoistways.

Preserve Heritage Buildings

Flexibility in design enables Garaventa's designers to adapt an inclined platform lift to virtually any building site with very little or no structural modifications. The availability of many colors and finishes ensures the lift will blend with its environment and preserve the look of a heritage building.

Save Valuable Floor Space

Floor space within a business building or a school is a valuable commodity. The X3 utilizes very little of this premium space.

Meets ADA Requirements

Garaventa inclined platform lifts are recognized in the ADA Accessibility Guidelines as a means to provide public building access when licensed for independent operation. They may also be used as an accessible means of egress when equipped with an auxiliary standby power system.

Design Assistance

With over 25 years of experience, Garaventa Lift is willing and able to overcome almost any design challenge you face. Please call our Design Hot Line with your accessibility challenge.

1-800-663-6556 or **1+604-594-0422**

How It Works

The platform of the X3 travels along two custom designed aluminum rails that can be mounted either directly to the wall or to support posts (towers). The upper rail houses a gear rack while the lower rail provides lateral support. The platform is propelled by means of a carriage mounted rack and pinion drive system.

Finishes

Standard Color

The X3 rails and loading ramps are made of champagne anodized aluminum. The non-aluminum components of the lift are finished in a durable polyester powder paint coating that is electrostatically applied and baked at 210° C (410° F). Garaventa Lift standard color, Satin Grey (fine textured), compliments a variety of modern and traditional decors (color samples are available upon request). The conveyance cover is made of black colored high quality ABS/PVC.

Optional Colors

Garaventa also offers a choice of colors from the internationally accepted RAL color charts (color samples are available upon request). Please note the conveyance cover is not painted. Custom paint finishes available, contact your local Garaventa Lift Representative.

Platforms

The platform is available in four standard sizes, with a rated load of 250 kg (550lbs.) evenly distributed around the center of the platform.

Platform Sizes:

- 800 X 1220 mm (31 1/2" X 48") **ADA**
- 800 X 1050 mm (31 1/2" X 41 3/8")
- 800 X 900 mm (31 1/2" X 35 1/2")
- 700 X 750 mm (27 1/2" X 29 1/2")

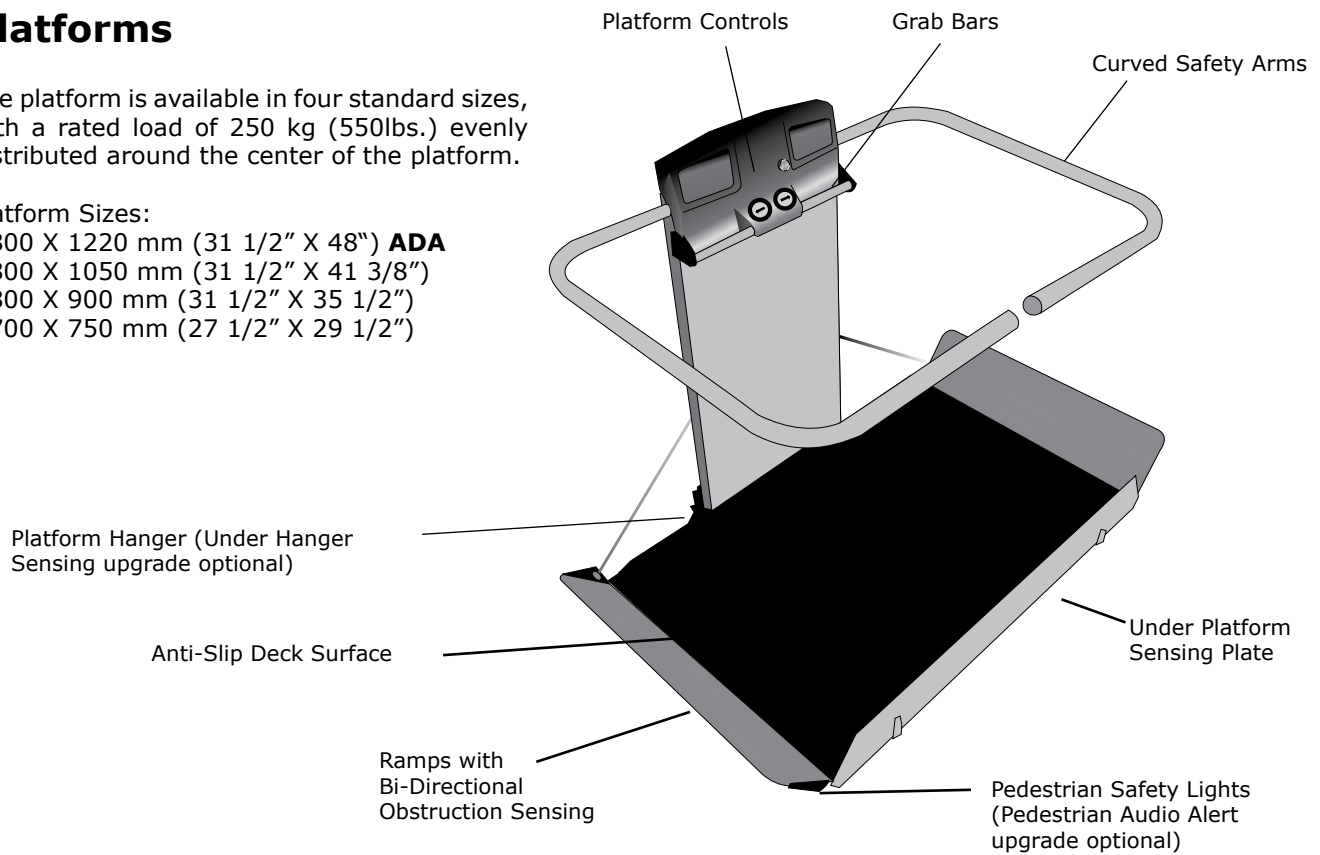

Platform Components

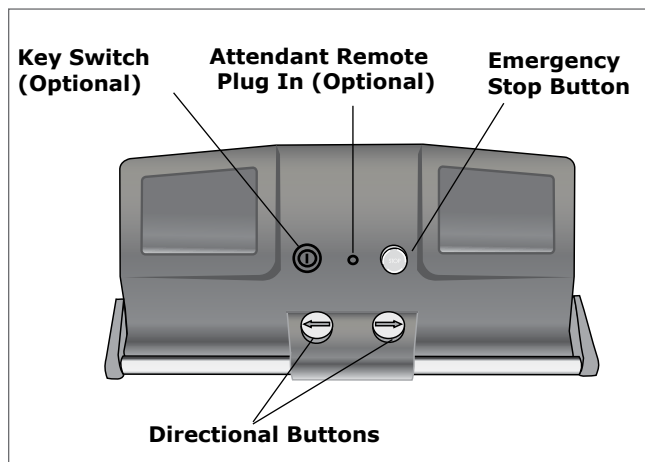

Platform Control Panel

The durable and vandal resistant platform control panel is mounted to the platform hanger. The standard platform controls consist of two large illuminated constant pressure **Directional Buttons** for independent operation and an **Emergency Stop Button** (with illumination optional).

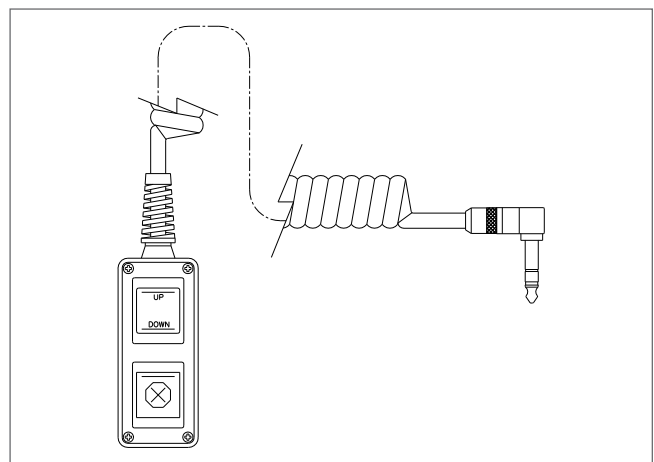

Attendant Remote Control Unit

The platform can be equipped with an optional **Attendant Remote Control** that overrides the constant pressure **Directional Buttons** during attendant operation. The remote control unit can be removed when not required.

Standard Platform Features

Emergency Stop Button

Located on the platform control panel, this red button is used to stop the lift in an emergency.

Overspeed Safety

The over speed safety which is located in the upper carriage on the platform, consists of a mechanical pawl and electrical cutout switch. In the unlikely event that the lift should descend too quickly, both the mechanical and electrical safety will activate simultaneously and stop the platform from moving.

Leading Ramp Sensor

The leading ramp is sensitive to obstructions. The ramps are designed to be obstruction sensitive in the direction of travel on the outside of the ramps as well as from within the platform. The internal ramp sensor prevents a wheelchair from being off-center on the platform deck.

Under Platform Sensing Plate

The under platform sensing plate detects obstacles underneath the platform.

Platform Grab Bar

This safety feature increases the ease with which passengers may load and unload from the platform.

Emergency Fold

In an emergency the platform is able to be manually folded and will lock in the folded position.

Curved Safety Arms

Manual (residential) or fully automatic (commercial) curved safety arms further increase the safety of the X3 inclined platform lift.

Hour Counter

The hour counter enables the owner to determine the amount of time the X3 inclined platform lift has been used. This is a helpful tool in determining times for preventive maintenance.

Keyless Platform

Standard platform operation is keyless

Manual Emergency Lowering

Lift is equipped with manual hand wheel to allow the platform to be lowered in case of an emergency or power loss.

Optional Platform Features

Note: In some areas certain optional features are either not permitted or mandatory depending on local codes. Please consult your local Garaventa Lift representative for clarification.

Folding Seat Assembly

The folding seat is equipped with a safety belt.

Side Load

Designed for confined lower landing areas, this feature opens a side ramp simultaneously with the end ramp. This allows the passenger to wheel onto the platform diagonally offering easier access.

On Board Alarm With Illuminated E-Stop Button

The emergency stop button can be illuminated and activate an onboard alarm.

Keyed platform

This option is designed for protection against unauthorized usage of the lift.

Platform lock

This is an additional safety feature that locks the platform and protects the unit from vandalism. The lock is manual for a manual platform (residential) and solenoid powered for an automatic platform.

Attendant Remote Control

The Attendant Remote Control overrides the directional buttons during attendant operation. The remote control unit can be removed when not required.

Platform Power Fold and Unfold

Platform can be folded and unfolded from the call stations by pressing the appropriate button. This is standard operation for a commercial X3 inclined platform lift.

Guide Rails

Two aluminum extrusions make up the guide rail assembly. The upper rail houses the rack that the platform's pinion gear utilizes for travel. The platform is mechanically attached to this upper rail. The lower rail is used as a guide track for the rollers of the lower carriage assembly. The upper and lower rail heights are based on the stair angle and the platform size. For more information on rail heights see page 10.

Call Stations

Wireless (Mandatory for Commercial Installs)

Each landing is equipped with a call station. The call station enables the user to call and send the platform with a touch of a button. Platform fold and unfold is possible with the fully automatic model.

Keyless Call Stations (Adjustable In Field)

This feature allows the user to operate the lift without a key.

Mounting Options

The call stations are mounted directly on the wall. Optional flush mount call stations are available. The optional flush call station box dimensions;

Length: 185mm (7 1/4")

Width: 115mm (4 1/2")

Depth: 52mm (2")

Directional
Buttons

Fold/
Unfold
Buttons

Key
Switch

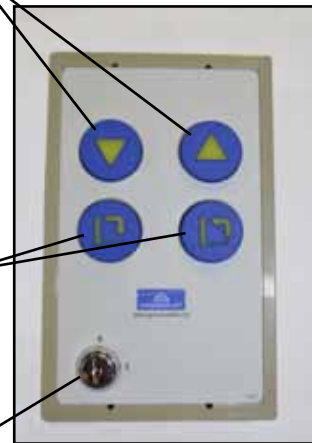

Minimum Site Dimension Requirements

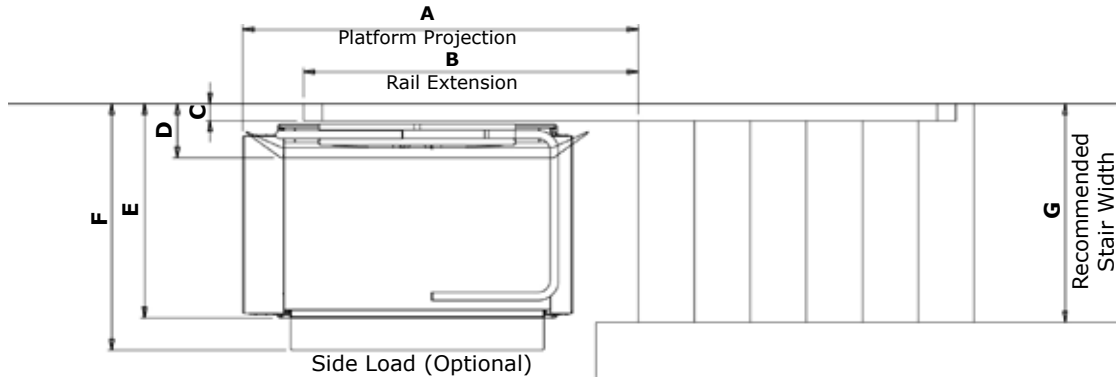

Note: Dimension F only applies at lower landing when the side load ramp is in the open position

Platform Projection and Rail Extensions

Stair Angle	15°	20°	25°	30°	35°	40°	45°
Dimension A - Platform Projection							
800 x 1220mm Platform (31 1/2" x 48") ADA	2321 91 3/8"	2082 82"	1936 76 1/4"	1837 72 3/8"	1764 69 1/2"	1708 67 1/4"	1664 65 1/2"
800 X 1050 (31 1/2" X 41 3/8")	2152 84 3/4"	1913 75 3/8"	1767 69 5/8"	1668 65 5/8"	1595 62 3/4"	1539 60 5/8"	1495 58 7/8"
800 X 900 (31 1/2" X 35 1/2")	2001 78 3/4"	1762 69 3/8"	1616 63 5/8"	1517 59 3/4"	1444 56 7/8"	1388 54 5/8"	1344 52 7/8"
700 X 750 (27 1/2" X 29 1/2")	1851 72 7/8"	1612 63 1/2"	1466 57 3/4"	1367 53 7/8"	1294 51"	1238 48 3/4"	1194 47"
Dimension B - Rail Extension							
800 x 1220mm Platform (31 1/2" x 48") ADA	2200 86 5/8"	1912 75 1/4"	1709 67 1/4"	1558 61 3/8"	1449 57"	1448 57"	1369 53 7/8"
800 X 1050 (31 1/2" X 41 3/8")	2116 83 1/4"	1828 72"	1625 64"	1474 58"	1365 53 3/4"	1364 53 3/4"	1285 50 5/8"
800 X 900 (31 1/2" X 35 1/2")	2040 80 3/8"	1752 69"	1549 61"	1398 55"	1289 50 3/4"	1288 50 3/4"	1209 47 5/8"
700 X 750 (27 1/2" X 29 1/2")	1965 77 3/8"	1677 66"	1474 58"	1323 52 1/8"	1214 47 3/4"	1213 47 3/4"	1134 44 5/8"

Note: These dimensions are based on a first riser height of **190mm (7 1/2")**. The platform projection and rail extension will be shorter than indicated for shallow stairs below 25° as they may have shorter first risers, please consult Garaventa Lift.

Stair Width Clearance for Different Attachment Methods

Clearance Width Dimensions	C Rail Protrusion		D Platform Folded		E Platform Unfolded		F Side Load Ramp		G Stair Width	
	mm	in	mm	in	mm	in	mm	in	mm	in
800 x 1220 (31 1/2" x 48") 800 x 1050 (31 1/2" x 41 3/8") & 800 x 900 (31 1/2" x 35 1/2") platforms										
Direct Mount	81	3 1/4	345	13 5/8	1040	41	1255	49 1/2	1060	41 3/4
Towers	146	5 3/4	410	16 1/8	1105	43 1/2	1320	52	1125	44 1/4
*700 x 750 mm (27 1/2" x 29 1/2") Platform										
Direct Mount	81	3 1/4	345	13 5/8	940	37	N/A	N/A	960	37 3/4
Towers	146	5 3/4	410	16 1/8	1005	39 1/2	N/A	N/A	1025	40 3/8

Attachment Methods

The extruded aluminum guide and support rails can be directly mounted to the wall or attached to steel support towers. There are various attachment methods used to support the X3.

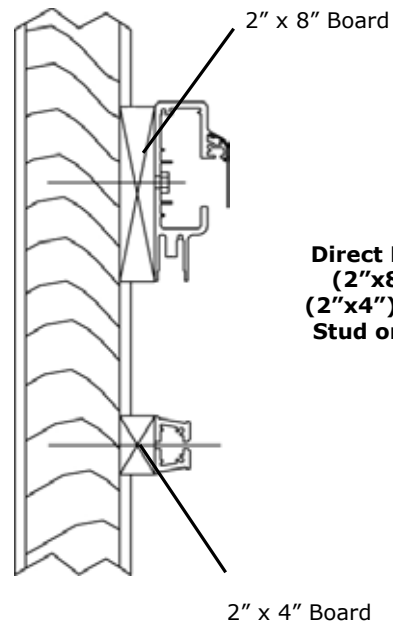
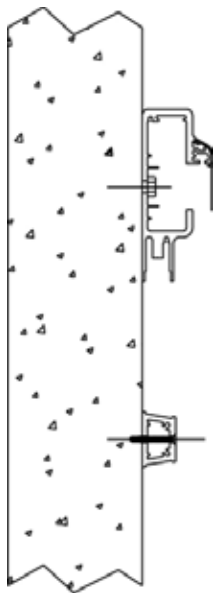

**Direct Mount to 50x200
(2"x8") and 50x100
(2"x4") Boards on Wood
Stud or Thin Block Wall**

Direct Mount Anchored to Solid Walls

- Solid concrete (152mm (6") thick minimum)
- Concrete block (203mm (8") minimum without reinforcement or 152mm (6") minimum with reinforcement)
- Wood support posts located in wall (4" x 6" min.) Locations determined by Garaventa Lift.
- Steel support posts located in the wall. 76mm x 76mm x 6mm wall / (3" x 3" x 1/4") minimum. Locations determined by Garaventa Lift.

Direct Mount Anchored to Wood Stud or Thin Block Walls

The upper rail must be attached to a 2" x 8" board that is secured to the wall. For the lower rail, a 2" x 4" board can be used. Each board must be fastened into every available wall stud with minimum two screw fasteners.

Note: Not Suitable for Steel Stud Applications.

Attachment Methods (Continued)

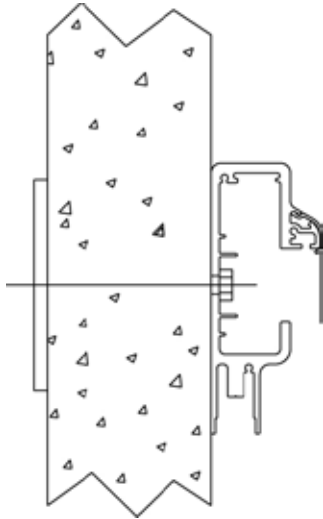

**Thin Structural Wall
(Through-Bolting
may be applied)**

Freestanding Support Towers

Required where no support walls exist, or when the lift must be located away from a wall structure.

- Solid concrete stairs/landings
- Wood stairs/landings over 76.2mm (3") thick
- Concrete steel pan treads (towers must be secured back to the stringer with brackets for extra support)

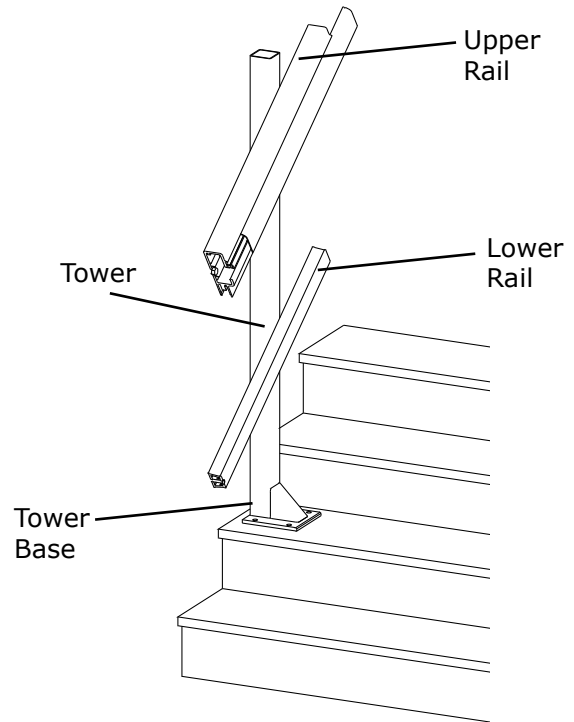

Open Balustrade (Towers in the core)

In situations where the stairs cannot support free-standing towers and where direct mounting is not feasible, it may be possible to install support towers in the open core. This may also be a solution where there is insufficient clearance with towers on the treads. The towers are fastened to the floor and secured to walls or stringers.

Overhead Clearances

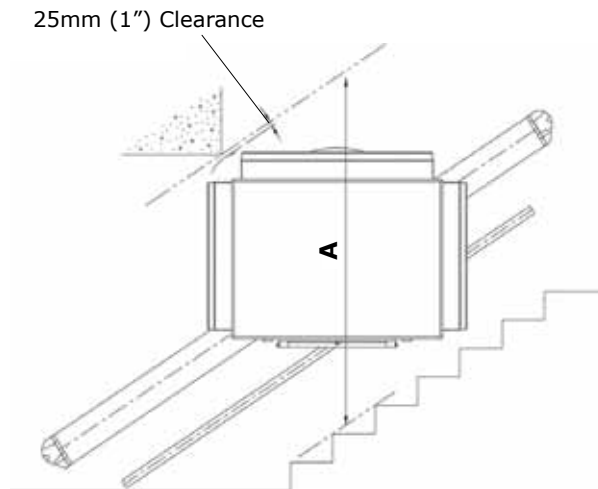

Overhead Clearances Required For Folded Platform

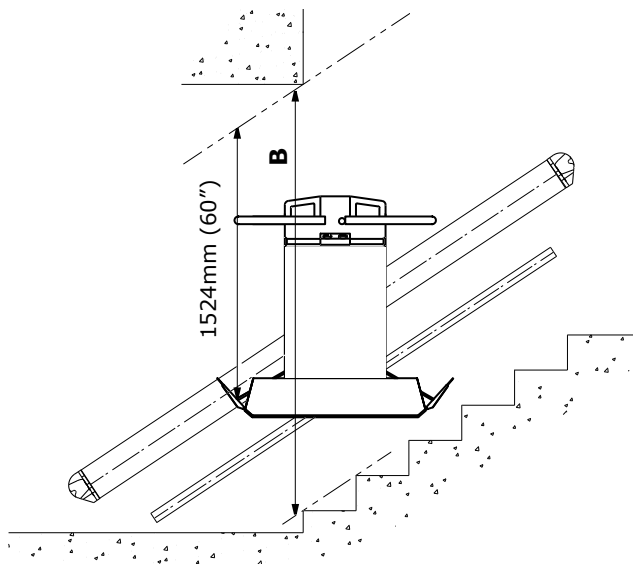

Overhead Clearances to meet US Code Requirements (ASME A18.1b)

Refer to page 12.

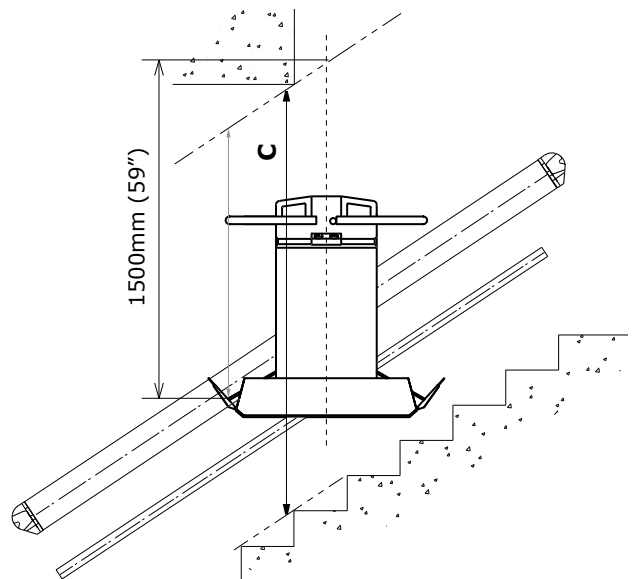

Overhead Clearances to meet Canadian Code Requirements (CSA B355-2000)

Refer to page 12.

Overhead Clearances

Stair Angle	15°	20°	25°	30°	35°	40°	45°
Dimension A - Platform Running Clearance							
800 x 1220mm Platform (31 1/2" x 48") ADA	1467 57 3/4"	1576 62"	1693 66 5/8"	1821 71 3/4"	1965 77 3/8"	2160 85"	2352 92 5/8"
800 X 1050 (31 1/2" X 41 3/8")	1422 56"	1514 59 5/8"	1614 63 1/2"	1723 67 7/8"	1846 72 5/8"	2018 79 1/2"	2218 87 3/8"
800 X 900 (31 1/2" X 35 1/2")	1382 54 3/8"	1460 57 1/2"	1516 59 5/8"	1636 64 3/8"	1740 68 1/2"	1891 74 1/2"	2067 81 3/8"
700 X 750 (27 1/2" X 29 1/2")	1324 52 1/8"	1383 54 1/2"	1448 57"	1519 59 3/4"	1598 62 7/8"	1688 66 1/2"	1838 72 3/8"
Dimension B - US Code Requirements							
800 x 1220mm Platform (31 1/2" x 48")	1943 76 1/2'	2059 81 1/8"	2184 86"	2319 91 1/4"	2469 97 1/4"	2641 104"	2839 111 3/4"
800 X 1050 (31 1/2" X 41 3/8")	1898 74 3/4"	1998 78 5/8"	2105 82 7/8"	2221 87 1/2"	2351 92 1/2"	2499 98 3/8"	2670 105 1/8"
800 X 900 (31 1/2" X 35 1/2")	2040 80 3/8"	1752 69"	2035 80 1/8"	2134 84"	2245 88 3/8"	2372 93 3/8"	2519 99 1/8"
700 X 750 (27 1/2" X 29 1/2")	1817 71 1/2"	1888 74 3/8"	1965 77 3/8"	2048 80 5/8"	2140 84 1/4"	2246 88 3/8"	2369 93 1/4"
Dimension C - Canadian Code Requirements							
800 x 1220mm Platform (31 1/2" x 48")	1755 69 1/8"	1813 71 3/8"	1875 73 7/8"	1943 76 1/2"	2018 79 1/2"	2105 82 7/8"	2205 86 3/4"
800 X 1050 (31 1/2" X 41 3/8")	1733 68 1/4"	1783 70 1/4"	1836 72 1/4"	1894 74 5/8"	1960 77 1/8"	2034 80 1/8"	2121 83 1/2"
800 X 900 (31 1/2" X 35 1/2")	1712 67 3/8"	1755 69 1/8"	1801 70 7/8"	1851 72 7/8"	1907 75 1/8"	1970 77 5/8"	2045 80 1/2"
700 X 750 (27 1/2" X 29 1/2")	1692 68 5/8"	1728 68"	1766 69 1/2"	1808 71 1/4"	1854 73"	1907 75 1/8"	1970 77 1/2"

Wall Height Requirement for Direct Mounting

*True wall height is dimension **K** plus 35 mm (1 3/8").

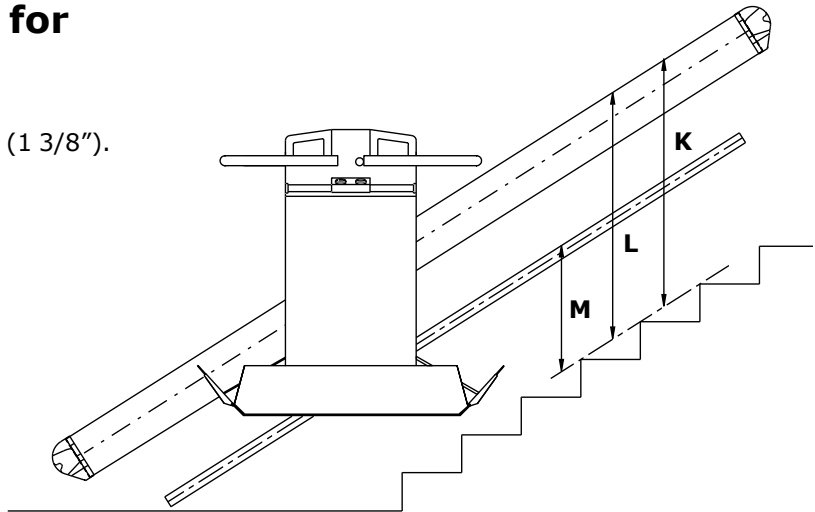

Stair Angle	15°	20°	25°	30°	35°	40°	45°
Dimension K - Min. Wall Height for Wall Mount							
800 x 1220mm Platform (31 1/2" x 48") ADA	1092 43"	1152 45 3/8"	1217 47 7/8"	1289 50 3/4"	1371 54"	1464 57 5/8"	1574 62"
800 X 1050 (31 1/2" X 41 3/8")	1069 42 1/8"	1122 44 1/8"	1178 46 3/8"	1241 48 7/8"	1312 51 5/8"	1394 54 7/8"	1490 58 5/8"
800 X 900 (31 1/2" X 35 1/2")	1049 41 1/4"	1094 43 1/8"	1143 45"	1197 47 1/8"	1255 49 3/8"	1320 52"	1414 55 5/8"
700 X 750 (27 1/2" X 29 1/2")	1029 40 1/2"	1067 42"	1108 43 5/8"	1153 45 3/8"	1207 47 1/2"	1267 49 7/8"	1339 52 3/4"
Dimension L - Upper Rail Height							
800 x 1220mm Platform (31 1/2" x 48")	1057 41 5/8"	1117 44"	1182 46 1/2"	1254 49 3/8"	1336 52 5/8"	1429 56 1/4"	1539 60 5/8"
800 X 1050 (31 1/2" X 41 3/8")	1034 40 3/4"	1087 42 3/4"	1143 45"	1206 47 1/2"	1277 50 1/4"	1359 53 1/2"	1455 57 1/4"
800 X 900 (31 1/2" X 35 1/2")	1014 39 7/8"	1059 41 3/4"	1108 43 5/8"	1162 45 3/4"	1224 48 1/4"	1295 51"	1379 54 1/4"
700 X 750 (27 1/2" X 29 1/2")	994 39 1/8"	1032 40 5/8"	1073 42 1/4"	1118 44"	1172 46 1/8"	1232 48 1/2"	1304 51 3/8"
Dimension M - Lower Rail Height							
800 x 1220mm Platform (31 1/2" x 48")	398 15 5/8"	456 18"	520 20 1/2"	590 23 1/4"	667 26 1/4"	756 29 3/4"	859 33 7/8"
800 X 1050 (31 1/2" X 41 3/8")	375 14 3/4"	426 16 3/4"	481 18 7/8"	541 21 1/4"	608 23 7/8"	685 27"	775 30 1/2"
800 X 900 (31 1/2" X 35 1/2")	355 14"	398 15 5/8"	445 17 1/2"	497 19 5/8"	555 21 7/8"	622 24 1/2"	699 27 4/8"
700 X 750 (27 1/2" X 29 1/2")	335 13 1/4"	371 14 5/8"	410 16 1/8"	454 17 7/8"	502 19 3/4"	559 22"	624 24 5/8"

X3 Loading Diagram

Based on 800x1220 (31 1/2" x 48") platform

F1= 129 kg =>1265 N

F2= 250 kg (550 lb) (max. loading capacity) => 2452 N

d1= 360mm (14 1/8")

d2= 565mm (22 1/4")

x= 81.75mm (3 1/4")

F = F1+F2 = 1179 + 2452 = F = 3717 N

Moment over F1 & F2:

$M = F1 * (d1+x) + F2 * (d2+x) \Rightarrow M = 2251 \text{ Nm}$

Pulling Force F3:

$F3 = M / (d3+d4) \Rightarrow F3 = 2810 \text{ N}$

Pushing Force F4:

$F4 = M / d4 \Rightarrow F4 = 3752 \text{ N}$

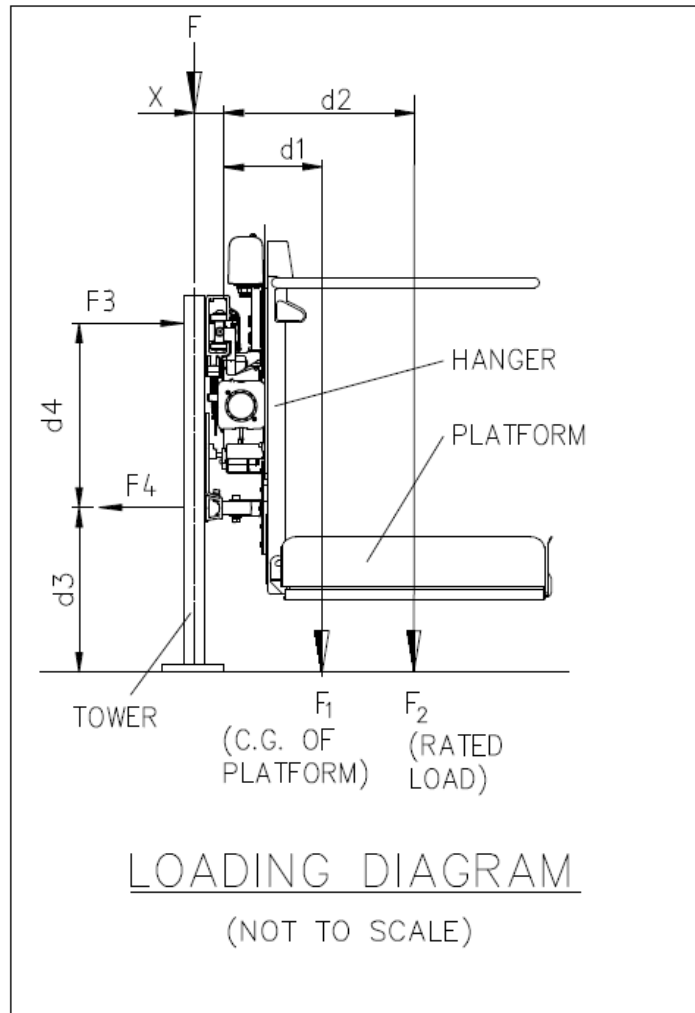

X3 Technical Reference

Application

Straight stairways

Platform Sizes

800 x 1220mm (31 1/2" x 48") - ADA Compliant
800 x 1050mm (31 1/2" x 41 3/8")
800 x 900mm (31 1/2" x 35 3/8")
700 x 750mm (27 1/2" x 29 1/2")

Rated Load

250 kg. (550 lbs.)

Speed

4 meters (13 ft) per minute

Operating Controls

Call Stations: Wireless, keyed (STD) call stations with encoded communication to stair lift. Powered by a regular 9 Volt battery. Call station are mandatory for commercial installations.

Platform Controls: Keyless (STD) with constant pressure switches, 24 VDC, equipped with emergency stop switch.

Drive System

Motor: 24 Volt PMDC Motor with 374 W and IP 54 protection

Power Requirements: 2 x 12 VDC, 7.2Ah Batteries (residential) 18.0Ah (public package) in a housing located behind the conveyance

Charger: 120 VAC, 50Hz, single phase providing 2 amp charging current to unit.

Power Transmission: Rack & Pinion

Emergency Use: Handwheel is provided

Rail System

Champagne anodized aluminum extrusion with integrally mounted zinc plated gear rack.

Overspeed Safety

Mechanical overspeed sensor and brake, with electrical drive cut-out protection.

Curved Safety Arms

Fully automatic, 32mm (1 1/4") diameter safety arms, top of arm 948mm (37 3/8") above platform deck.

Pedestrian Safety Lights

Illuminated tube lighting, located at both ends of the platform deck. Alerts pedestrians that the platform is in motion.



Creating An Accessible World

 Printed in Canada
21040-F-DP

© Garaventa Lift. As we are continuously improving our products, specifications outlined in this brochure are subject to change without notice.

www.garaventalift.com

Authorized Garaventa Lift Representative