

# ELVORON CPL

## DESIGN AND PLANNING GUIDE



### **Please note:**

---

Dimensions provided in this Guide are for **REFERENCE ONLY** and should not be used for site preparation or construction.

---

# Elvoron CPL Table of Contents

<b>Elvoron CPL</b> .....	4
<b>Hoistway Construction</b> .....	5
Wood Construction .....	7
Masonry Construction .....	7
Door Openings .....	7
<b>Construction of Pit</b> .....	8
Pit Lighting .....	8
<b>Layouts &amp; Clearances</b> .....	9
<b>Elvoron Overview</b> .....	15
<b>Technical Information</b> .....	16
<b>Hydraulic Drive System</b> .....	17
Lighting .....	18
Electrical Disconnects .....	18
Ventilation Requirements .....	18
Mains Power Requirements .....	18
Emergency Battery Lowering .....	18
Emergency Manual Lowering .....	18
<b>Construction of Machine Room &amp; Electrical Requirements</b> .....	19
<b>Features &amp; Options</b> .....	21
Car Operating Panel .....	21
Hands Free Telephone (Optional) .....	21
Hall Stations .....	21
Egg Crate Ceiling & Cabin Lights .....	22
Safety Features .....	22
Hall Doors & Interlocks .....	23
Hall Doors - Power Swing Door Operator (Optional) .....	23

## Elvoron CPL

The Elvoron Commercial Platform Lift is a sophisticated hydraulic elevating system designed specifically for use in small commercial buildings. The system fits within a vertical hoistway connecting the floors to be serviced. A small machine room or machine cabinet outside the hoistway is required to accommodate the controller and pump unit. This area can be adjacent to the hoistway or in a remote location. Details may be affected by local code.

The platform lift stops level with the bottom floor thus a small pit is required. The recommended pit depth is 9-1/4" (235 mm). A pit depth of 12" (305mm) is required for cabs with 1400 lb capacity and clear cab widths greater than 42" (1067mm).

At the upper landing, an overhead clearance of 96" (2438mm) is required for our standard cab height of 84" (2134mm). For taller custom cab heights adjust your overhead accordingly.

This Design Guide is intended to assist architects, contractors, and elevator professionals in planning for the Elvoron CPL.

We strongly recommend you contact your local Garaventa Lift representative to discuss and become familiar with the local code requirements in your area. It is extremely important to know and adhere to all local codes and regulations pertaining to the installation and use of Commercial Platform Lifts.

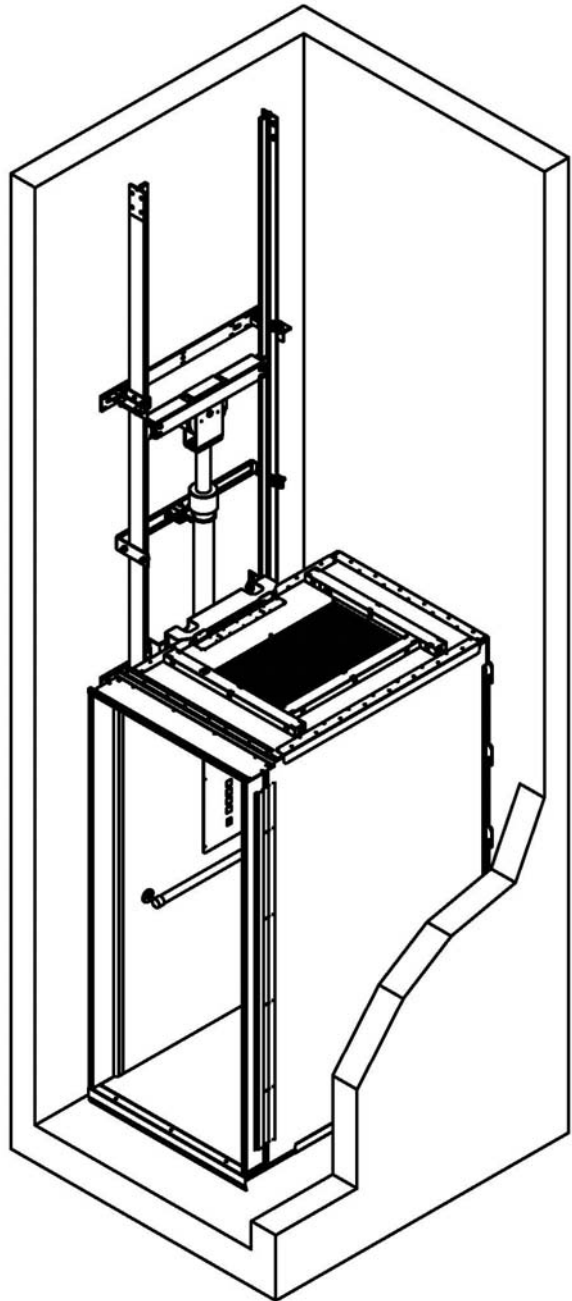

## Hoistway Construction

The walls of the hoistway can be constructed of wood, poured concrete or concrete block. The wall behind the cylinder and guide rails must be load bearing and able to withstand the loads imposed by the lift.

The cylinder and guide rails are mounted to the wall with steel brackets. These rail brackets are fastened to the load bearing wall at regular intervals. See shop drawings for locations.

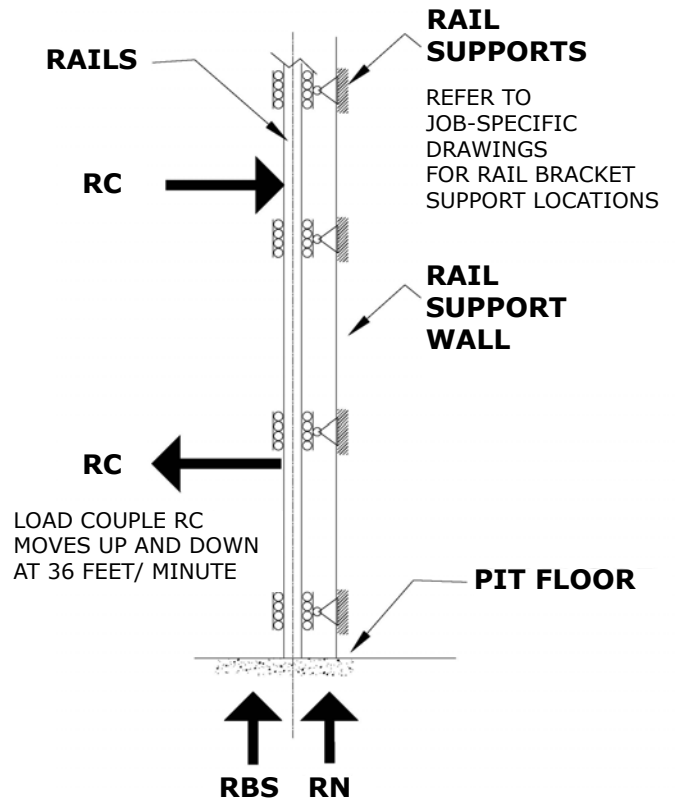
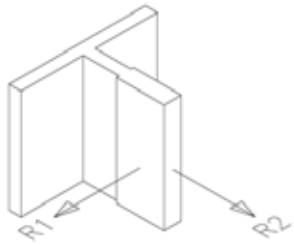

Load	Description	Capacity		
		750 lbs lbf (KN)	1000 lbs lbf (KN)	1400 lbs lbf (KN)
<b>RBS</b>	Reaction due to buffer or safety engagement	4777 (21.4)	5278 (23.7)	6077 (27.2)
<b>RN</b>	Reaction due to normal operation	2927 (13.1)	3178 (14.2)	3577 (16.0)
<b>RC</b>	Load imposed during normal or emergency operation maximum pull-out force on rail support	520 (2.3)	609 (2.7)	753 (3.4)
<b>R1</b>	Rail Reaction	260 (1.2)	305 (1.4)	376 (1.7)
<b>R2</b>	Rail Reaction	63 (0.3)	83 (0.4)	117 (0.5)

The rail bracket spacing is determined during the design phase. The rail brackets are generally every 4' or 8' apart, measured vertically, depending on the load capacity, size of cab and travel height. Please see final elevator shop drawings for actual locations.

All the walls of the hoistway, especially the wall behind the rails and the entrance walls, need to be flush and plumb from floor to ceiling. This is to allow for the required running clearances.

No light is required at the top of the hoistway. A light is required in the pit (see Construction of Pit for details).

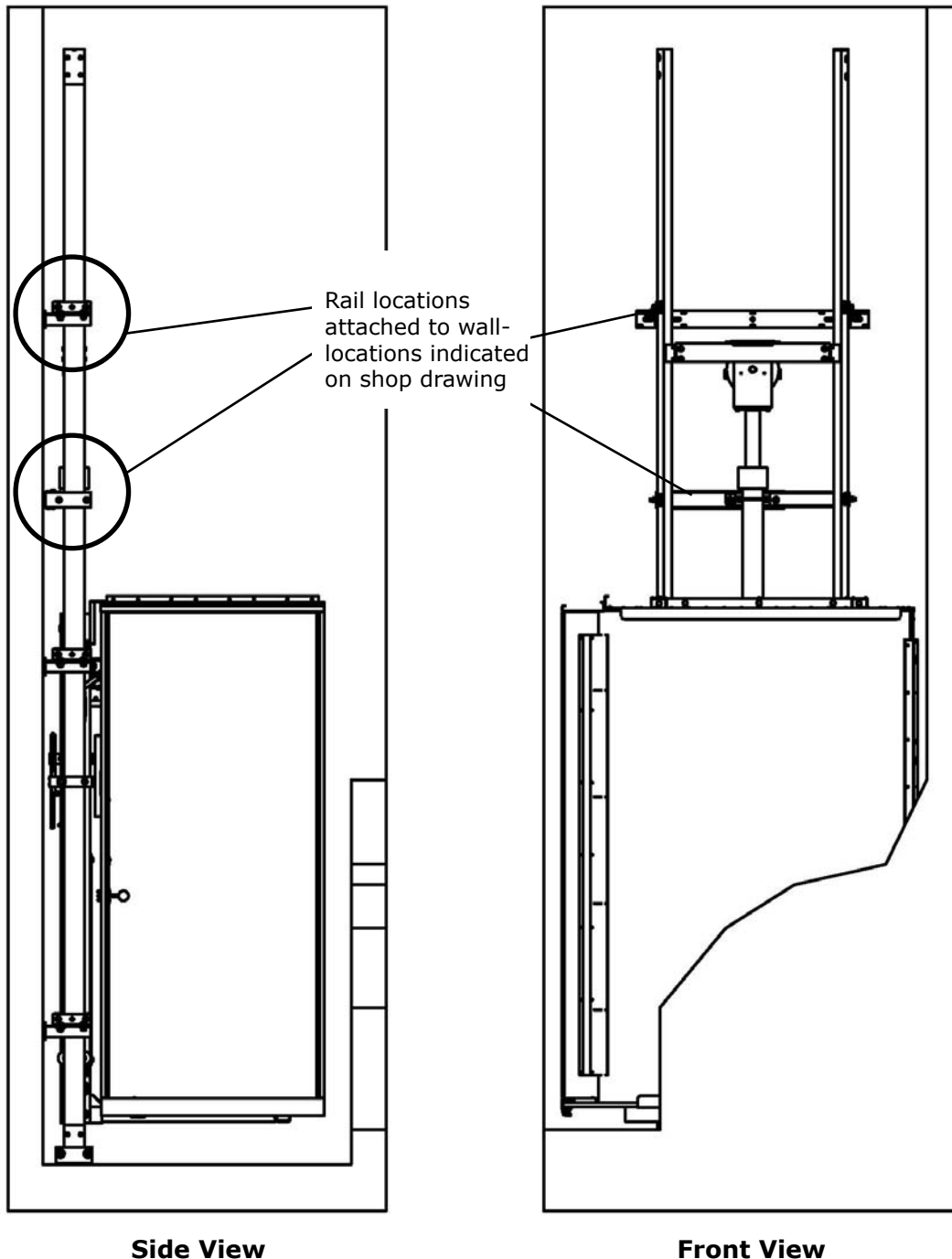

**Wood Construction**

The wall behind the rails must be structural to withstand the loads defined in the loading diagram. Garaventa Lift recommends vertical blocking for mounting rail brackets. Vertical blocking should be a minimum of two 2" x 12"s laid flat and fastened between two 2x4's.

The hoistway dimensions indicate the clear inside finished cavity. Please ensure you allow for Hoistway finishing.

**Masonry Construction**

It is not necessary to make the return portion of the walls in concrete. We suggest you make them of steel and use T-bar to support the lintels. This makes it easier to finish around the door frames after they have been placed.

**Door Openings**

Do not construct the return walls on either side of the door entrances until after the doors and frames have been aligned on site.

The rails, cylinder, and platform are installed and then the doors are aligned to the center of the platform.

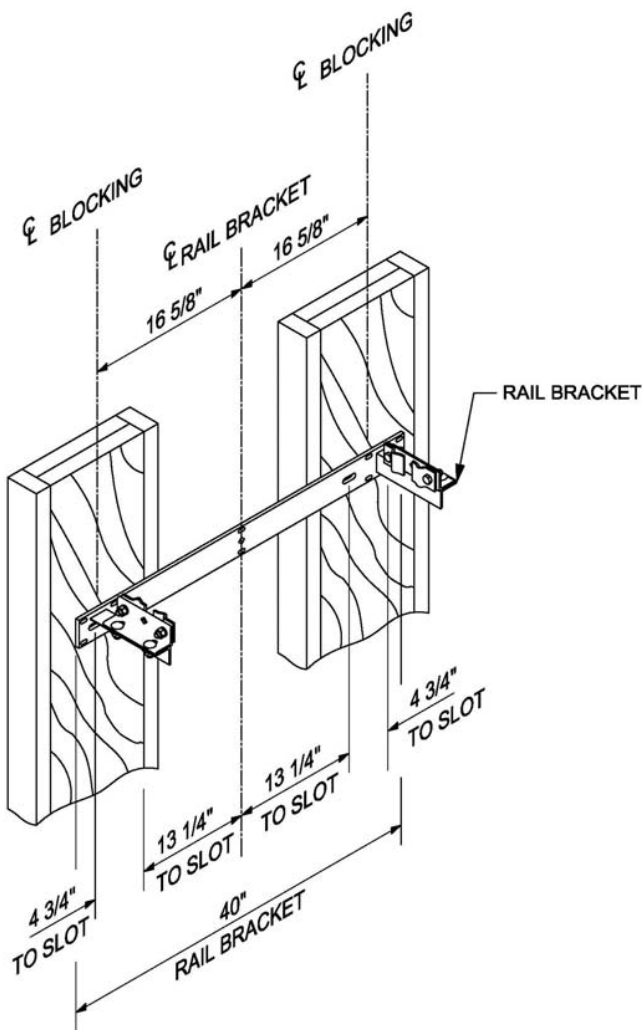

**Wood Blocking Guidelines**

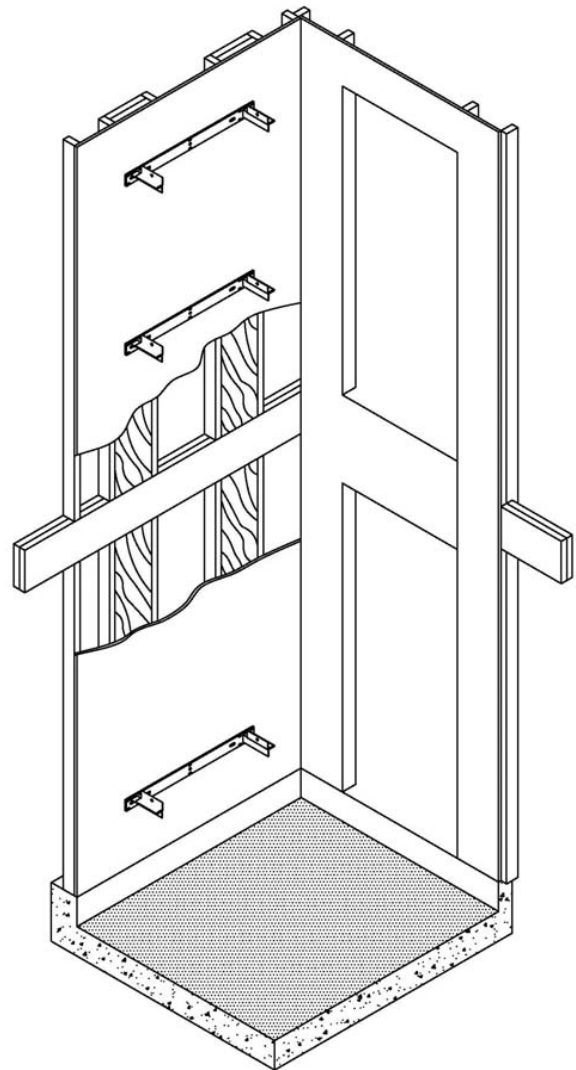

**Rail Bracket in Hoistway**

## Construction of Pit

The pit must be the same width and length as the hoistway, and should have a minimum 4" thick concrete floor. The majority of the weight of the lift is borne by the plunger (ram). Reactions are indicated on each project's shop drawings. Pit depth of 9-1/4" (235 mm) is typical for most cabs.

A pit depth of 12" (305mm) is required for cabs with 1400 lb capacity and clear cab widths greater than 42" (1067mm).

If there is habitable space under the hoistway then Buffer Springs are required by code. This will increase the pit depth by 2".

A **pit ladder** is required only if the pit depth exceeds 35" (915mm). Consult your Garaventa Lift representative for details as changes to finished hoistway are required.

### Pit Lighting

A pit light is required if the illumination level is less than 50 lx at the pit floor with the lowest door open. The general contractor can install a light in the hoistway pit or provide 110v duplex receptacle within 10' (3000 mm) of either jamb of the lowest landing door.

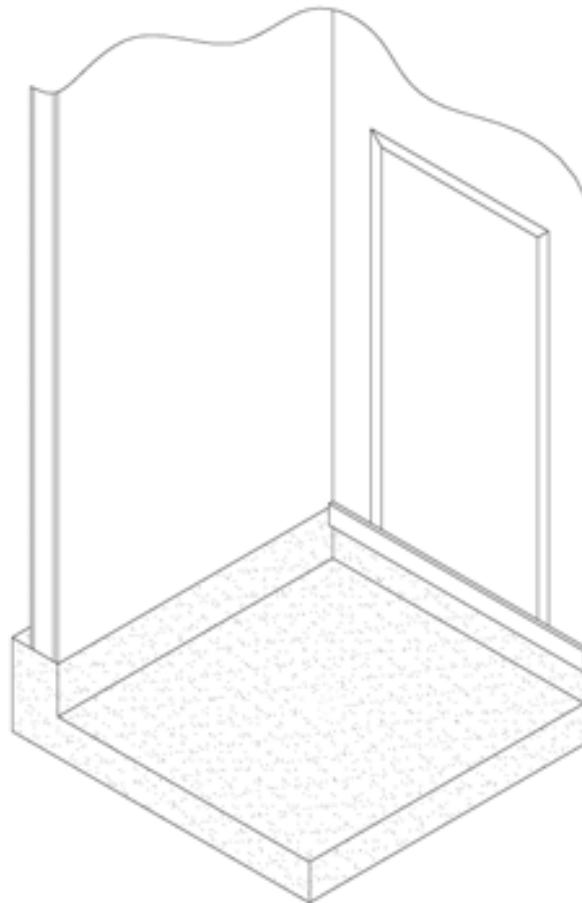

## Layouts & Clearances

**On / Off Same Side  
Configuration Style 1R:**

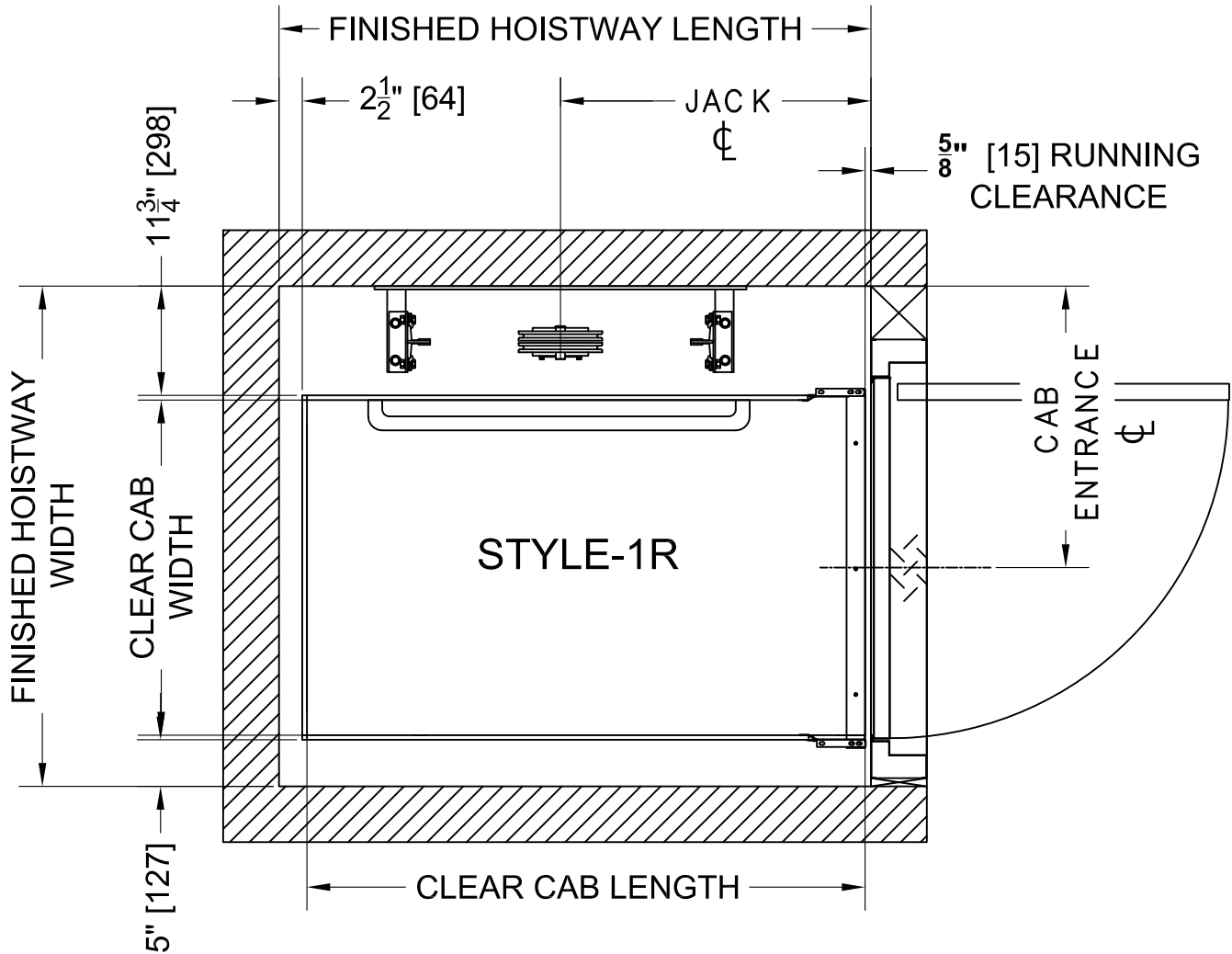

Clear Cab Size	Hoistway Width	Hoistway Length	Jack Centerline	Entrance Centerline
36 x 60	53 3/4	63 5/8	33 3/8	30 1/4
42 x 60	59 3/4	67 5/8	35 3/8	36 1/4
48 x 60*	65 3/4	67 5/8	35 3/8	42 1/4

\* Where permitted by local code, state or provincial authority

## Layouts & Clearances

On / Off Same Side  
 Configuration Style 1L:

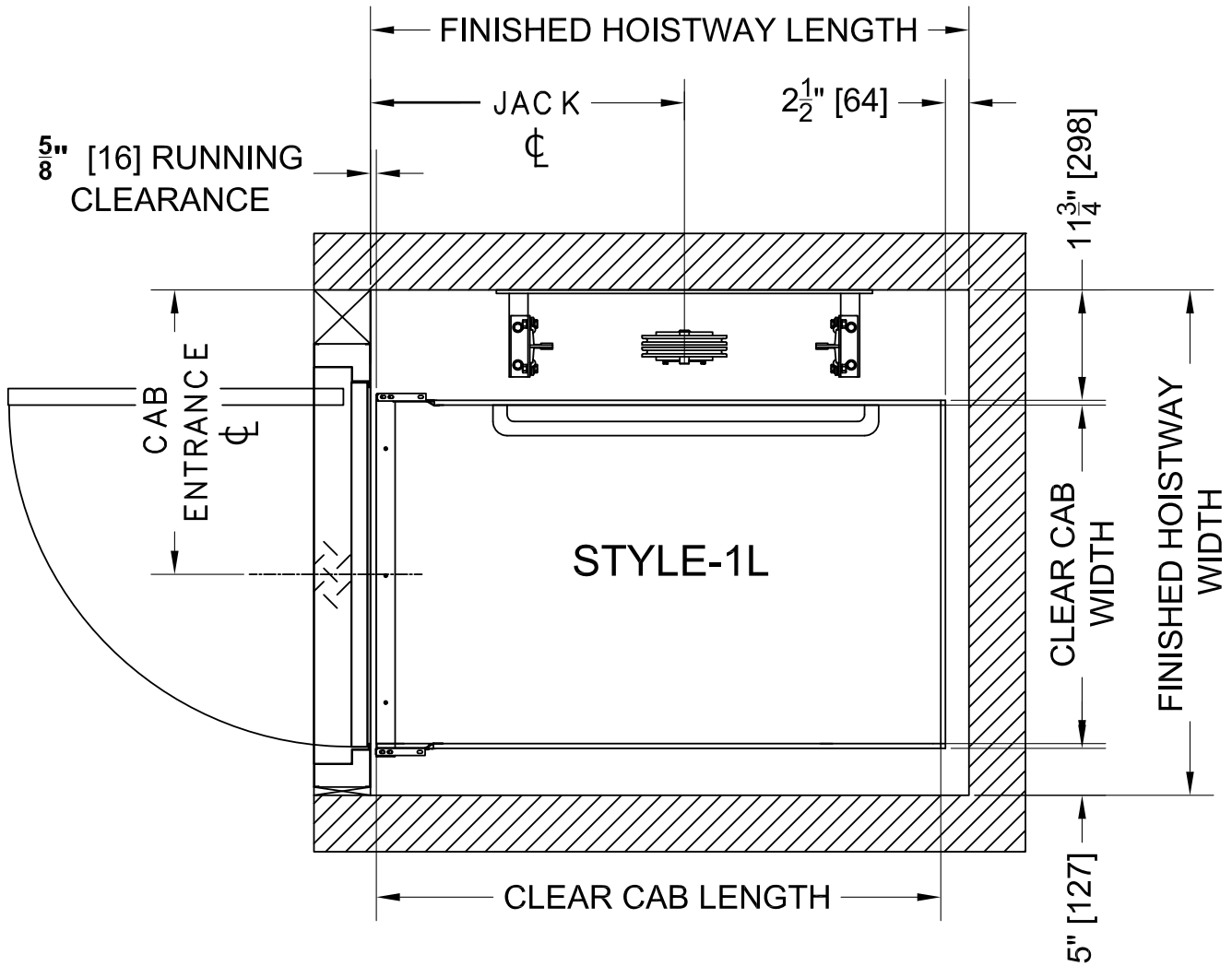

Clear Cab Size	Hoistway Width	Hoistway Length	Jack Centerline	Entrance Centerline
36 x 60	53 3/4	63 5/8	33 3/8	30 1/4
42 x 60	59 3/4	67 5/8	35 3/8	36 1/4
48 x 60 *	65 3/4	67 5/8	35 3/8	42 1/4

\* Where permitted by local code, state or provincial authority

## Layouts & Clearances

### Straight Through Configuration Style 2:

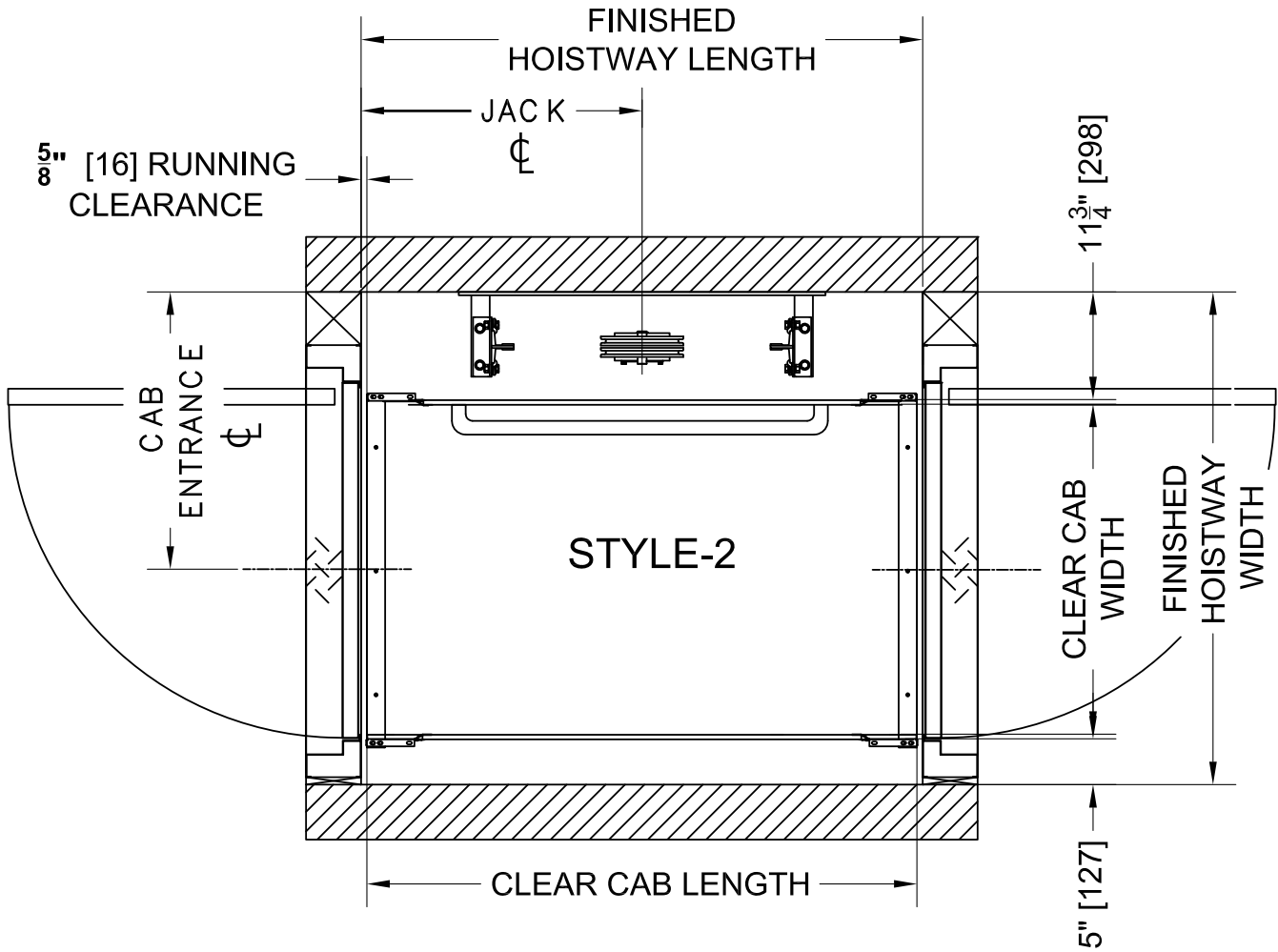

Clear Cab Size	Hoistway Width	Hoistway Length	Jack Centerline	Entrance Centerline
36 x 60	53 3/4	61 1/4	30 5/8	30 1/4
42 x 60	59 3/4	69 1/4	34 5/8	36 1/4
48 x 60 *	65 3/4	69 1/4	34 5/8	42 1/4

\* Where permitted by local code, state or provincial authority

## Layouts & Clearances

### 90° Entry / Exit Configuration Style 3:

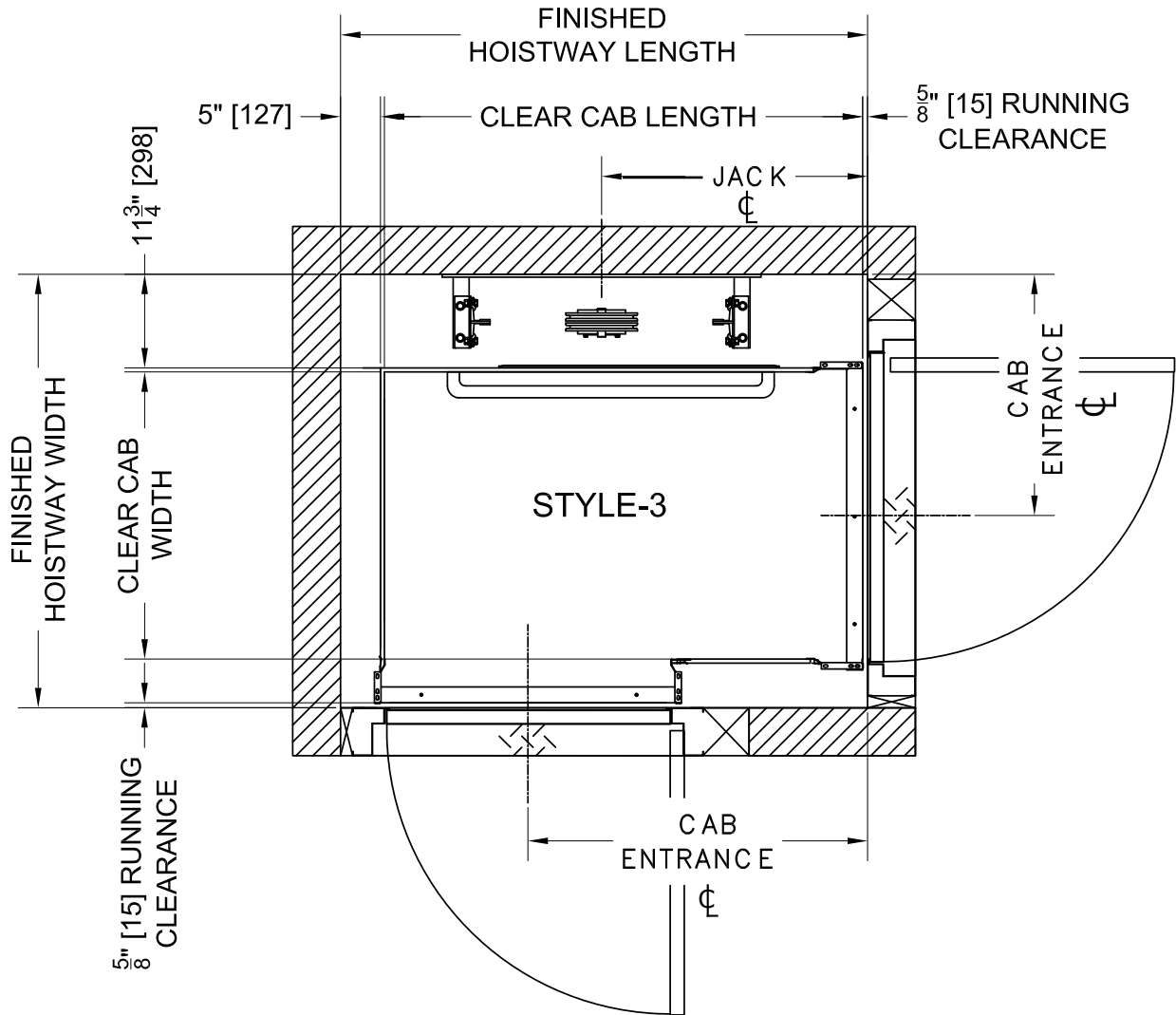

Clear Cab Size	Hoistway Width	Hoistway Length	Jack Centerline	Entrance Centerline	Entrance B Centerline
36 x 60	54 3/8	66 1/8	33 3/8	30 1/4	42 5/8
42 x 60	60 3/8	70 1/8	35 3/8	36 1/4	42 5/8
48 x 60 *	66 3/8	70 1/8	35 3/8	42 1/4	42 5/8

\* Where permitted by local code, state or provincial authority

## Layouts & Clearances

### 90° Entry / Exit Configuration Style 4:

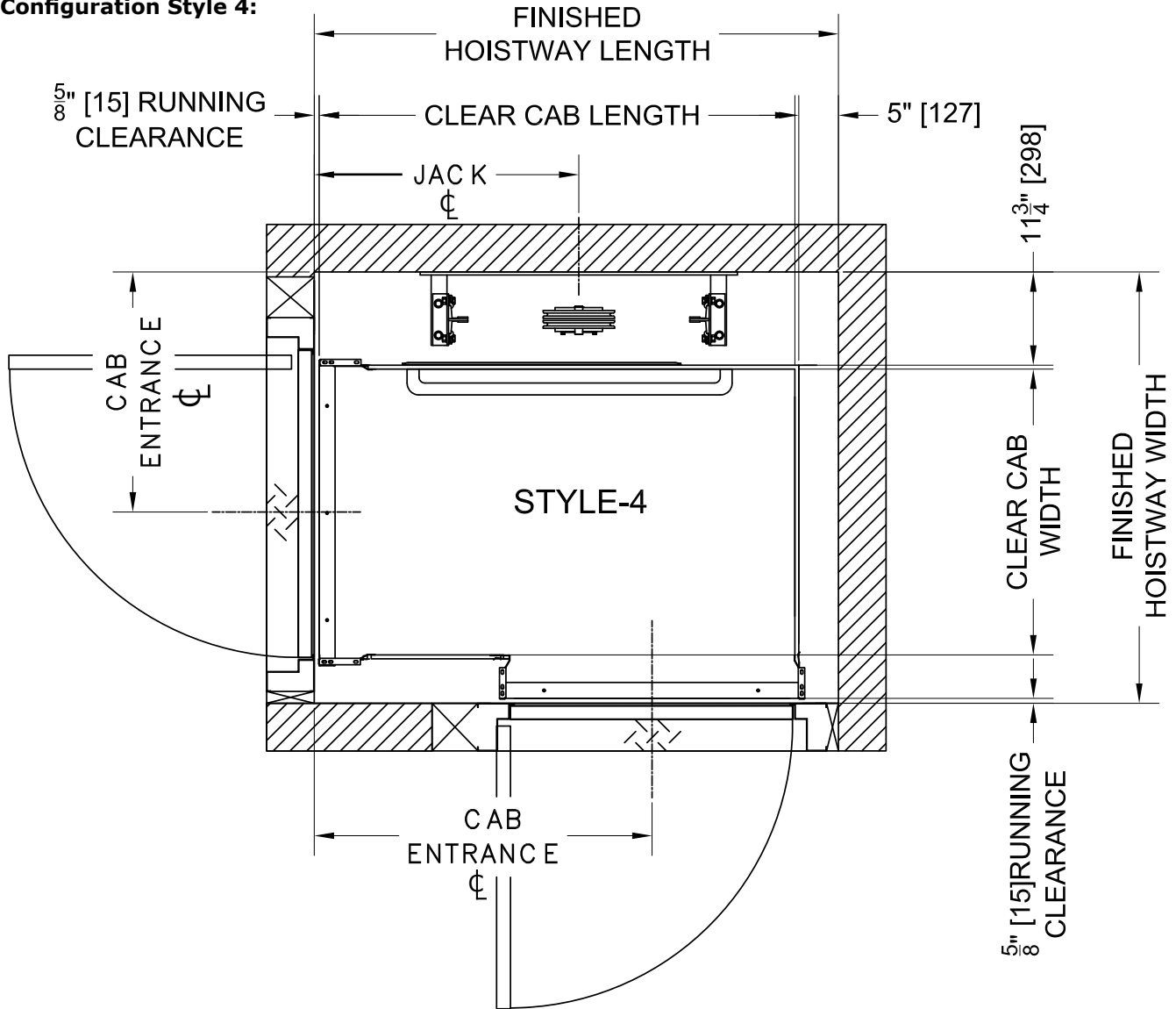

Clear Cab Size	Hoistway Width	Hoistway Length	Jack Centerline	Entrance Centerline	Entrance B Centerline
36 x 60	54 3/8	66 1/8	33 3/8	30 1/4	42 5/8
42 x 60	60 3/8	70 1/8	35 3/8	36 1/4	42 5/8
48 x 60 *	66 3/8	70 1/8	35 3/8	42 1/4	42 5/8

\* Where permitted by local code, state or provincial authority

## Layouts & Clearances

### On / Off Same Side Front Configuration Style 5:

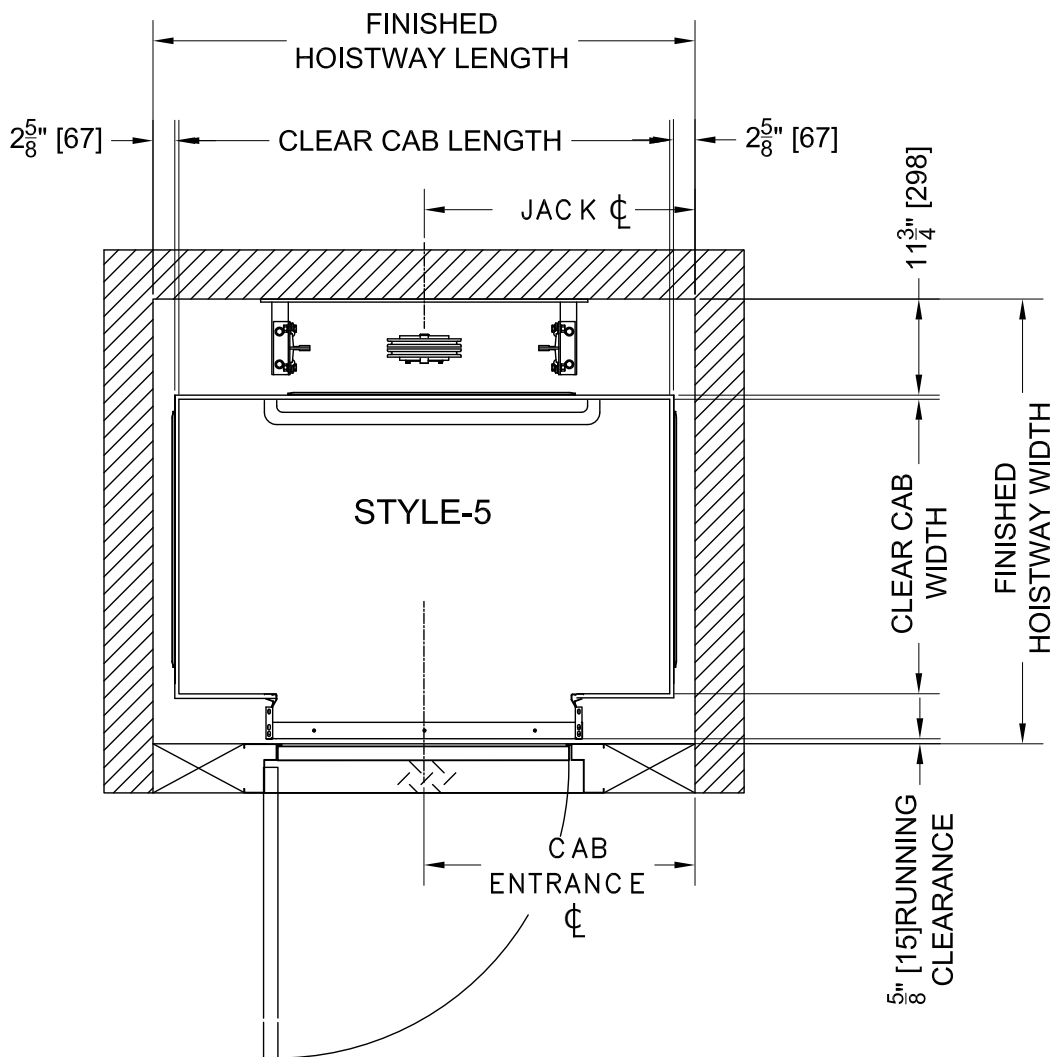

Clear Cab Size	Hoistway Width	Hoistway Length	Jack Centerline	Entrance Centerline
36 x 60	54 3/8	66 1/4	33 1/8	33 1/8
42 x 60	60 3/8	66 1/4	33 1/8	33 1/8
48 x 60 *	66 3/8	66 1/4	33 1/8	33 1/8

\* Where permitted by local code, state or provincial authority

## Elvoron Overview

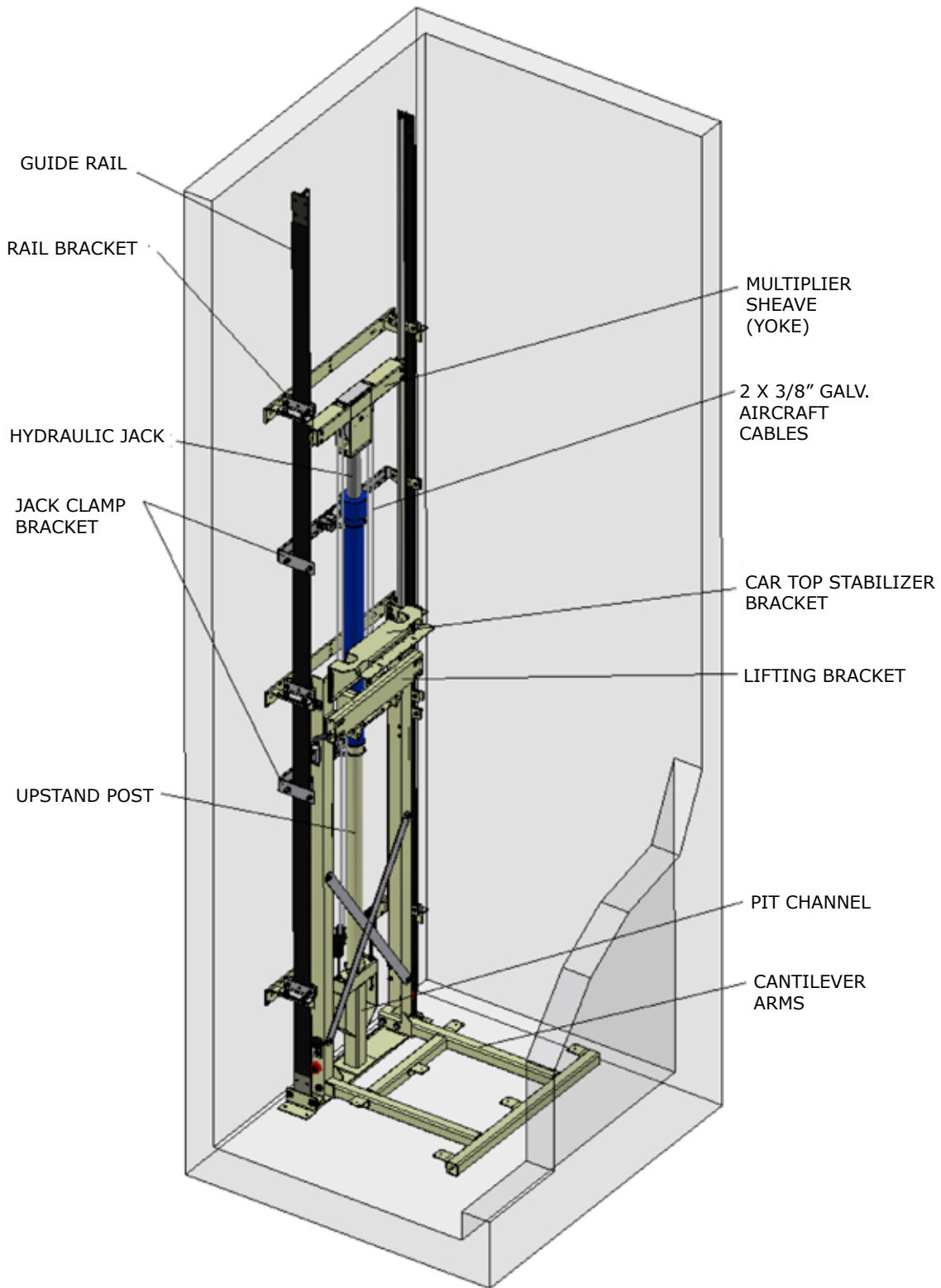

## Technical Information

### Car Sizes:

- 36" x 60" (914 x 1524mm)
- 42" x 60" (1067 x 1524mm)
- 48" x 60" (1220 x 1524mm)

### Rated Load:

- Standard: 750 lbs (340 kg)
- Option 1: 1000 lbs (455 kg)
- Option 2: 1400 lbs (635 kg)\*

### Speed:

- Standard: 30 fpm (0.15 m/s) nominal speed
- Option: 40 fpm (0.2 m/s)\*

### Travel Range:

Canada - CSA B355: 23ft (7.0 meters)  
United States - A18.1: 14 ft (4.2 meters)  
Option: 50 ft (15.2 meters)\*  
Minimum distance between floors is 10" (254mm)

### Stops:

Up to 6 stops

### Pit Depth:

- 9-1/2" (235mm)
- Larger car sizes and heavier rated loads could increase pit depth to 12" (305mm)

### Required Overhead:

Overhead clearance of 96" (2438 mm) from upper landing with standard 84" (2134 mm) cab

### Drive System:

- 1:2 Cable Hydraulic
- Heavy duty car sling with roller guide shoes running on 8 lb. per foot steel T-rails
- Quiet submersed pump and motor
- Factory pre-set and tested 2-speed valve for smooth start and stop
- Single stage Hydraulic drive and two 3/8" aircraft cables

### Power Supply:

- Elevator: Standard: 208 VAC three phase  
Option: 230 VAC single phase
- Lighting: 110 VAC single phase, 15 amps

### Controls:

- Constant Pressure button operation (floor selective)
- Garaventa-Design PLC Controller
- Integrated self-diagnostics
- Digital floor indicator in car
- Automatic car lighting upon entry
- Illuminated push buttons
- Low oil protection timer circuit

### Hoistway Doors:

36" (914mm) wide swing doors, fire rated and flush on the inside of the hoistway.

### Safety Features:

- Emergency backup power lowering system
- Emergency manual lowering valve
- Safety brake system
- Automatic bi-directional floor leveling
- Emergency stop and alarm button in car
- Final limit switch

### Code Compliance:

- ASME A18.1, Platform Lifts and Stairway Chair Lifts.
- CSA B355 & B613, Safety Standard for Lifts for Persons with Physical Disabilities
- ADA (Americans with Disabilities Act)

### Popular Options:

- Automatic door operators
- Integrated hands free telephone
- Custom car finishes
- Additional handrails
- Buffer springs (increases your pit depth)
- Pipe rupture valve
- Remote machine room

**\*Contact Garaventa Lift**

## Hydraulic Drive System - Machine Room & Electrical Requirements

In order to satisfy code requirements, the hydraulic pump unit and fused disconnect switches must be located in a room or area which is lockable. A lockable cabinet is acceptable. However, to meet electrical code, Service Personnel must have the following clearance in front of the electrical box:

**US** - 36" x 36" x 7' (915 x 915 x 2135mm)

**Canada** - 39<sup>3/8</sup>" x 39<sup>3/8</sup>" x 7' (1000 x 1000 x 2135mm)

The machine room does not have to be a separate, dedicated room. The machinery could be located in a closet or under the stairs, as long as the above requirements are met. The optimum location is at the lowest level, adjacent to the hoistway, preferable on the same side as the guide rails. The dimensions of the pump unit are 23" wide x 16 1/2" deep x 59 1/4" high (585 x 420 x 1505 mm).

To save space the electrical control box can be disconnected from the tank. They can be separated up to 10' (3048 mm) away. The control box is 23" wide x 6" deep x 30" high (585 x 155 x 765 mm). The tank for the pump and motor is 23" wide x 16 1/2" deep x 31" high (585 x 420 x 790 mm). You will need 4" (155 mm) above the pump and motor tank for servicing purposes.

One PVC sleeve, at least 4" (105 mm) in diameter, will be required between the hoistway and the machinery for the hydraulic hose and electrical conduit. This is to enable the installers to make the connection between the cylinder and the pumping unit. The sleeves should enter the hoistway at either corner of the support wall.

Please contact your local Garaventa Lift representative for specific local code requirements.

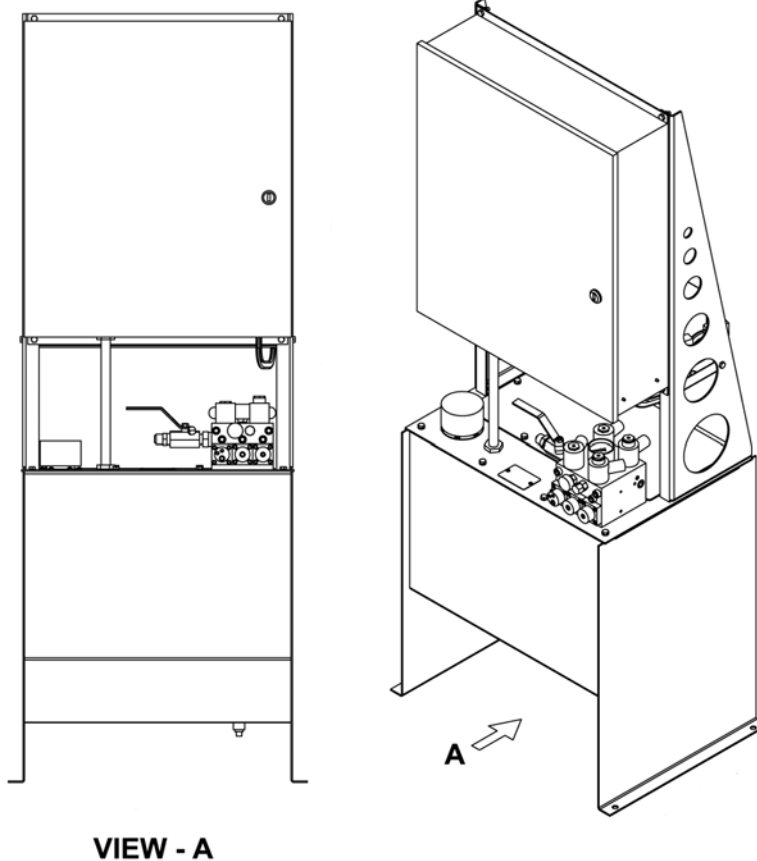

### **Lighting**

You must provide at least 100 lx lighting over the pumping unit and disconnect switches.

### **Electrical Disconnects**

In the machine room, you will need to provide two separate lockable fused disconnects – one 15 amp for lighting and one 30 amp for the pumping unit. Disconnect switches should be located on the lock jamb side of the machine room door. In accordance to the electrical code, you must provide a minimum of 36" (915 mm) square in the US and 39 3/8" (1000 mm) square in Canada of working space in front of each disconnect switch.

The fused disconnect switch rating and fuse rating for the lift will be shown on the shop drawings for your project.

At least one GFCI duplex receptacle connected to a dedicated 15 amp branch circuit must be installed in the machine room.

### **Ventilation Requirements**

No special requirements needed. The elevator pump unit will generate approximately 3200 BTU per hour under normal operating conditions. Recommended temperature for elevator equipment is 50° – 90° F (15° – 32° C) and 5% – 90% non-condensing. Please contact your local Garaventa Lift representative for possible local code variations.

### **Mains Power Requirements**

The standard motor on the pump unit is 3 HP and it can be ordered to suit either single or three phase power.

- 230 VAC Single phase 30 amps
- 208 VAC Three phase 20 amps

### **Lighting Power Requirements**

- 120 VAC Single phase 15 amps

### **Emergency Battery Lowering**

In case of a power outage the elevator is provided with a second power source that allows the car to be lowered to the lowest landing. While descending, the car can stop and the passenger can exit the car at any landing along the way.

### **Emergency Manual Lowering**

The elevator can be manually lowered from the release valve located on the top of the Control assembly tank.



**Electrical Disconnects**

## Construction of Machine Room & Electrical Requirements

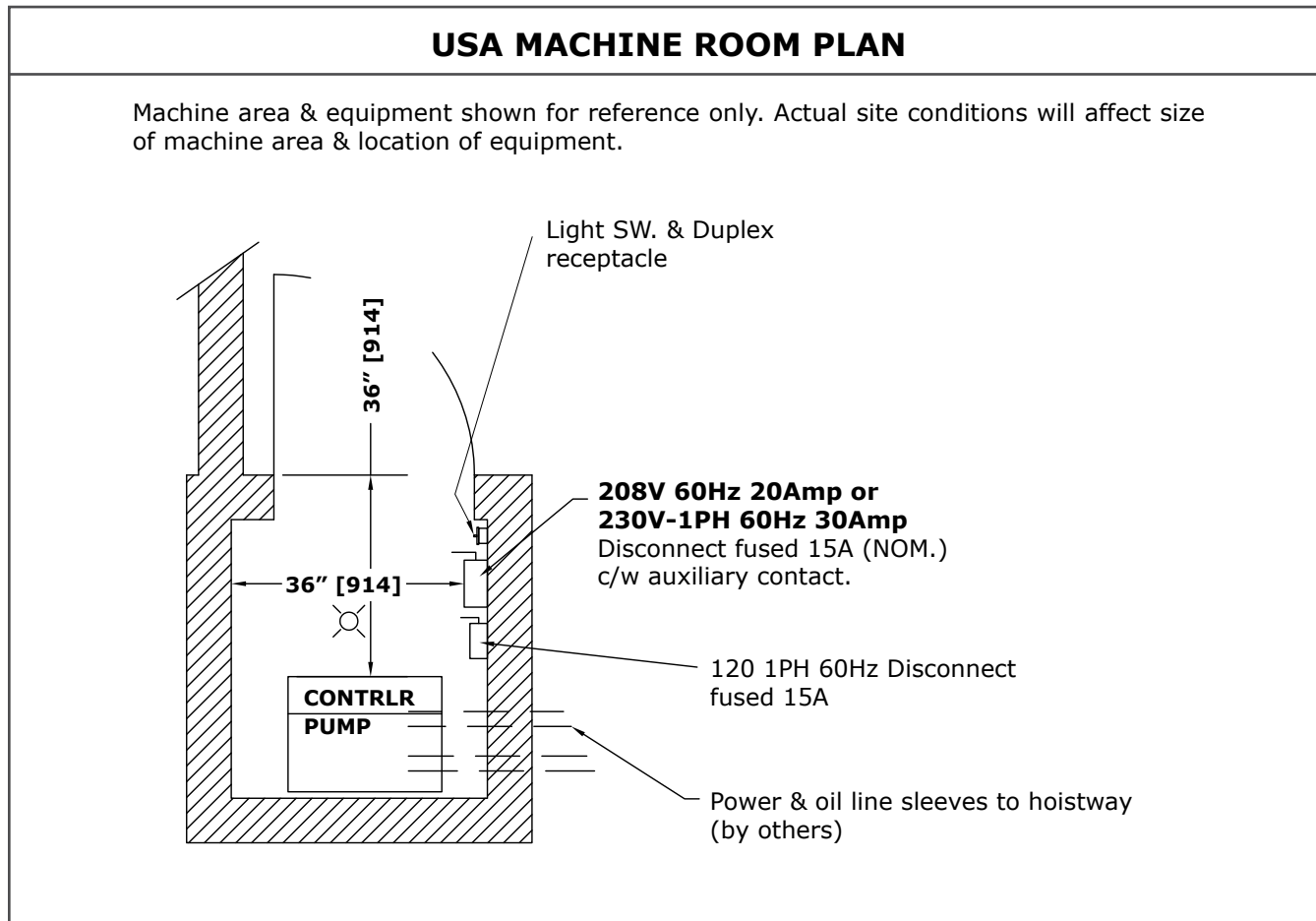

**Please contact your local Garaventa Lift Representative for specific Machine Room Code Requirements.**

## Construction of Machine Room & Electrical Requirements

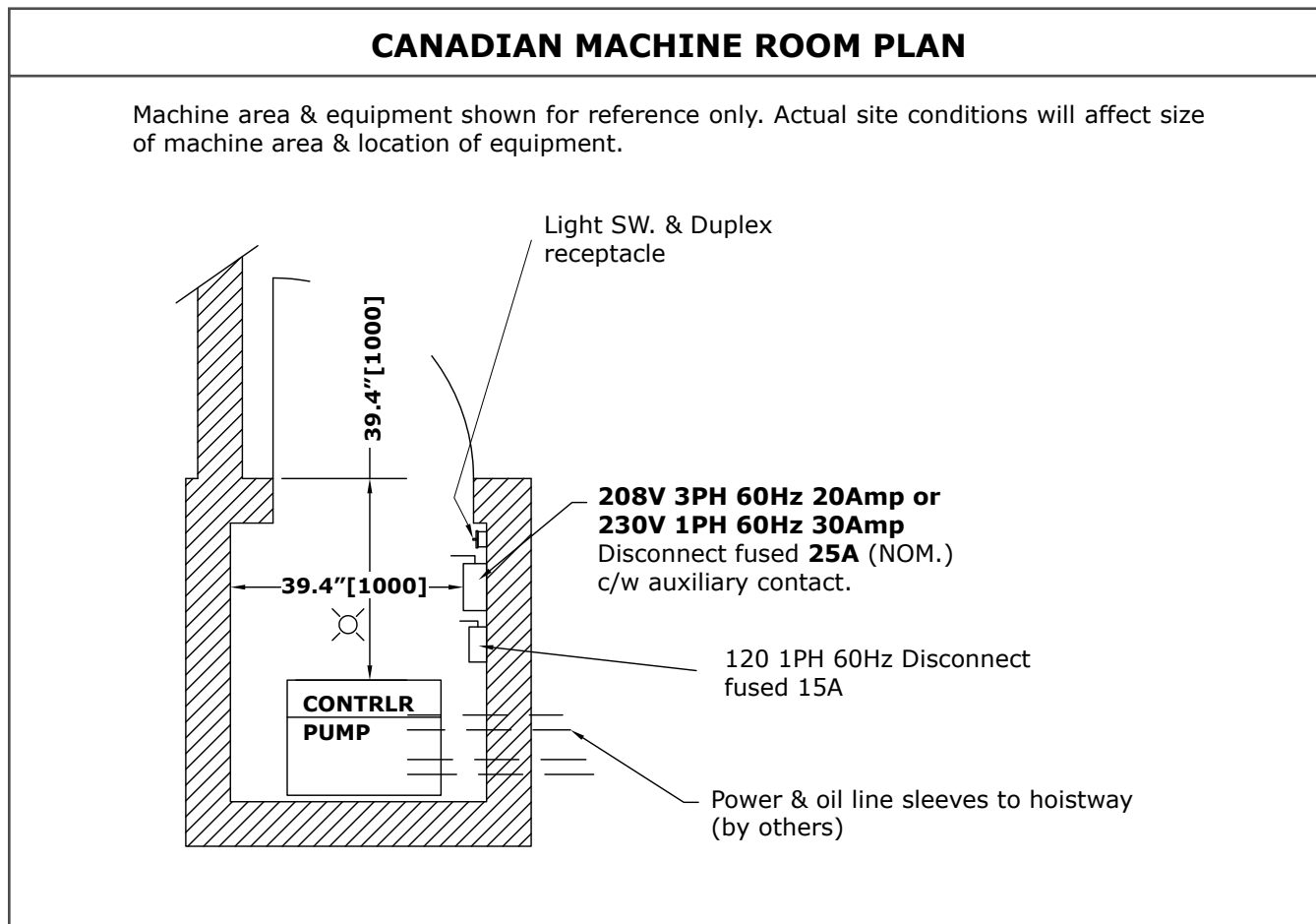

**Please contact your local Garaventa Lift Representative for  
specific Machine Room Code Requirements.**

## Features & Options

### Car Operating Panel

The COP is available in a variety of finishes. All COP's use constant pressure illuminated push button operation and are equipped with a digital position indicator and stop switch.

### Hands Free Telephone (Optional)

A hands free ADA telephone can be provided to meet local code requirements. The phone is mounted within the Car Operating Panel (COP) and is only visible as a phone button and speaker/ microphone.

### Hall Stations

The Hall Stations use constant pressure illuminated push buttons. Keyed hall stations maybe required to meet local code requirements. Please contact your local Garaventa representative to discuss local code requirements.

The hall stations are mounted within the door frame or they can be wall mounted for such cases when automatic power door operators are used on the landing doors or when more appropriate.

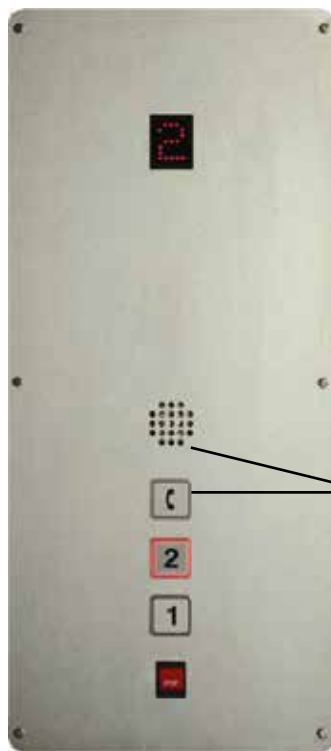

Hands Free Telephone

**Car Operating Panel**



**Frame Mounted Hall Stations**

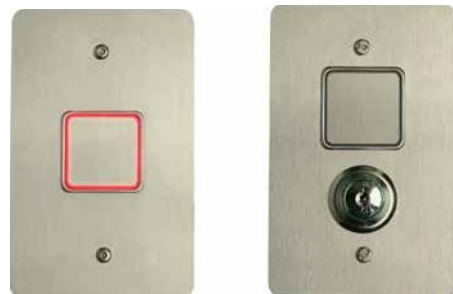

**Wall Mounted Hall Stations**

## Features & Options (Continued)

### Egg Crate Ceiling & Cabin Lights

The CPL is equipped with a non-load bearing ceiling, an "egg crate" style panel, to meet code requirement. The egg crate panel of the ceiling is bordered in white melamine.

Automatic cab lighting is provided as a standard feature. The 4 recessed pot lights, mounted into the border, are trimmed in white.

### Safety Features

- UPS provides back-up power to light the cab, lower the lift and open the hall door interlocks in the event of a power failure.
- A manual emergency lowering system is also provided for your safety.
- A slack rope/instantaneous safety system is provided to prevent free-fall of the elevator in the event of a rope failure.
- CSA Approved elevator interlocks are provided for each hall door. The interlock prevents an elevator door from being opened when the car is not at a landing. The elevator can not travel without all the hall doors closed and locked.
- Automatic bi-directional floor leveling ensures the car will stop and stay level with the landing regardless of the load on the elevator.
- CSA certified Elevator controller ensures the control meets the requirements of the ASME A17.1/CSA - B44 Safety Code for Elevators and Escalators.



## Features & Options (Continued)

### Hall Doors & Interlocks

Hoistway doors are located at each landing. They are equipped with an interlock to prevent the door from being opened if the cab is not at that landing.

These special doors and frames are mounted flush to the inside of the hoistway. This creates a plane running surface for the open entrance of the cab.

The solid steel core door has a vision panel, a pull handle on the outside, a push plate on the inside of the hoistway and an external closer.

The doors have a one and a half hour fire rating. They are galvaneal treated to be painted on site to match your building décor.

### Hall Door – Power Swing Door Operator (Optional)

Each hall door may be supplied with a power door operator. This feature will open the landing door when the cab arrives at a landing or when the hall station is pressed. The operator is mounted above the door frame and requires extra support or blocking and a separate 110 VAC power supply above the door header.





Creating An Accessible World

 Printed in Canada  
37159-F-DP

© Garaventa Lift. As we are continuously improving our products, specifications outlined in this brochure are subject to change without notice.

[www.garaventalift.com](http://www.garaventalift.com)

Authorized Garaventa Lift Representative