



ELVORON STELLA

RESIDENTIAL ELEVATOR



The Elvoron Stella Home Elevator is designed as a heavy-duty luxury residential elevator. It is fully automatic and has the same lifting mechanism and load capacity as a small commercial elevator. The Elvoron Stella features two speed sliding elevator doors and an increased load capacity of 1400 lbs..

DRIVE SYSTEM

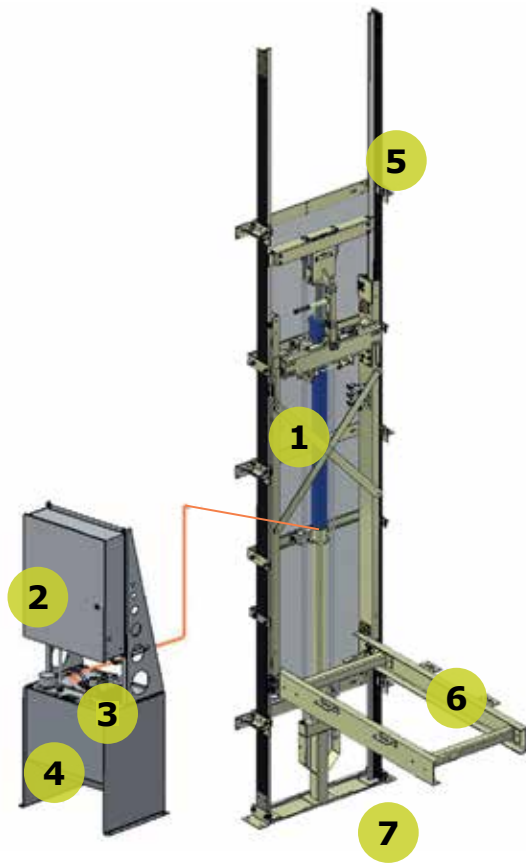

- 1** 1:2 Cable hydraulic drive with automatic leveling, emergency manual lowering and instantaneous safety brake system
- 2** Computerized (PLC) controller has an emergency backup power system for lowering in the event of power failure.
- 3** Two-speed hydraulic control valve provides smooth, comfortable starting and stopping.
- 4** Submersed hydraulic pump and 5 HP (3.5 Kw) motor ensures quiet operation.
- 5** Sturdy 8 lbs per foot elevator guide rail system ensures a smooth, quiet ride
- 6** Heavy duty cantilevered car support sling provides capacity of up to 1,400 lbs (635 kg).
- 7** Minimum pit depth is 14" (356 mm).

SPECIFICATIONS

Rated Load: 1400 lbs (635 kg) | Option 1000 lbs (455 kg)

Speed: Standard 40 fpm (0.2 m/s) nominal speed

Travel Range: 32 ft (9.75 m) with 1400 lb (625 kg) capacity | 36 ft (10.9 m) with 1000 lb (455 kg) capacity

Overhead Clearance (Refuge Space): 135"(3429mm) | 114" (2896mm) with car top prop

Drive System: 1:2 Cable Hydraulic | Heavy duty car sling with roller guide shoes running on 8 lb. per foot steel T-Rails | Quiet submersed pump and motor (5 HP) | Factory pre-set and tested 2-speed valve for smooth start and stop

Controls: Fully automatic push button operation | Garaventa-Design PLC Controller | Integrated self-diagnostics | Digital floor indicator in car | Automatic car lighting upon entry | Illuminated push buttons

Power Supply: Elevator: Standard 230 VAC single phase | Option 208 VAC three phase | Lighting: 110 VAC single phase, 15 amps

Doors: 36" x 80" (914mm x 2032mm) two-speed horizontal sliding hoistway and car doors

Safety Features: Emergency battery lowering system | Emergency manual lowering valve | Safety brake system Automatic bi-directional floor levelling | Stop keyswitch and alarm button in car | Final limit switch | Overspeed valve | Pit Prop

Unique Standard Features: Car direction lantern comes with audio and visual signals | Full height photo-electric door sensors

Code Compliance: ASME A17.1/CSA B-44 | Section 5.2 LU/LA Elevators. ADA (Americans with Disabilities Act)

Popular Options: Integrated telephone | Glass wall panels and a glass enclosure (panorama elevator) | Custom car finishes | Additional handrails | Buffer springs (increases your pit depth)

Warranty: 2 year standard warranty | Optional additional 5 year extended warranty (7 years)

FINISHES

Car Operating Panels



The Elvoron Stella COP is equipped with a digital floor indicator, illuminated floor buttons, alarm button, door open and close buttons and a keyed emergency stop switch. An optional integrated phone is available.

Car Direction Lantern



Mounted in the car doorway, the Car Direction Lantern is an audio and visual signaling device that indicates direction of travel and arrival at the floor.

Keyed Hall Station



Brushed
Stainless Steel
(standard)

Oil Rubbed
Bronze
(optional)

For increased safety and security, an optional key switch allows the entire elevator to be deactivated. Key switches can be custom designed to deactivate only certain hall stations or to control access to certain floors.

Lighting



Four recessed low-voltage L.E.D. light fixtures illuminate when the car gate is opened. Standard colors are white or black. Optional in chrome.

Handrails



Brushed
Stainless Steel
(standard)

Oil Rubbed
Bronze
(optional)

Available in two finishes, the handrail is located on the control wall. Custom finishes are available on request. Additional handrails can be mounted for extra passenger safety.

Hall Stations

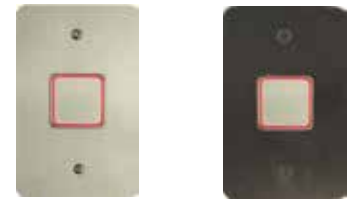

Brushed
Stainless Steel
(standard)

Oil Rubbed
Bronze
(optional)

The push buttons are made of stainless steel for maximum durability. Wall plates are available in two finishes, brushed stainless steel (standard) or oil rubbed bronze (optional).

Design Assistance



www.garaventalift.com



Design Hotline: 1.800.663.6556 Toll Free North America

ENTRY & EXIT CONFIGURATIONS

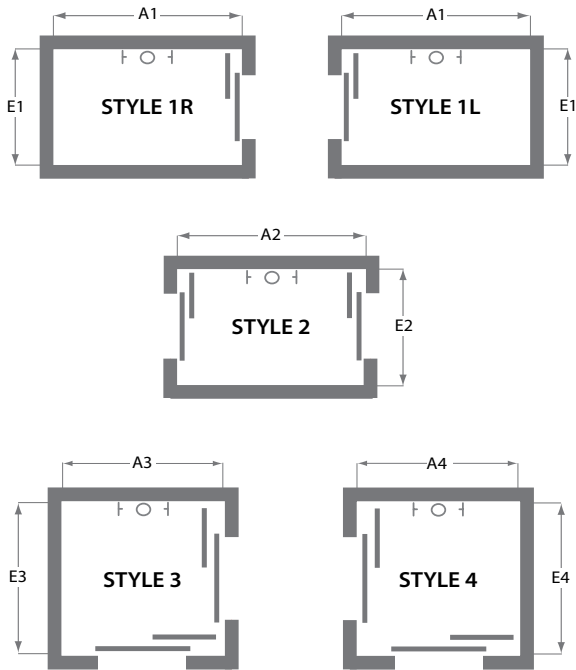

WALL FINISHES

Wood veneers



Plastic Laminates



Car Wall Trim Colors



HOISTWAY DIMENSIONS

Car Size	E1	A1	E2	A2	E3	A3	E4	A4
48" X 54" (1220 X 1372)	69"* (1753)	73" (1854)	69"* (1753)	81-1/2" (2070)				
42" X 60" (1067 X 1524)	69"* (1753)	79" (2007)	69"* (1753)	87-1/2" (2223)				
51" X 51" (1295 X 1295)					77-3/4" (1975)	72" (1829)	77-3/4" (1975)	72" (1829)

*66" (1676) hoistway width may be feasible. Consult with your local Garaventa Lift Representative



Contact us today:
(800) 663-6556 | garaventlift.com

© Garaventa Lift. As we are continuously improving our products, specifications outlined in this brochure are subject to change without notice. Due to the nature of the printing process, colors shown in the brochure may not be an accurate representation of the actual product.